

 **REMOTE START**

PUSH BUTTON
ELECTRIC START

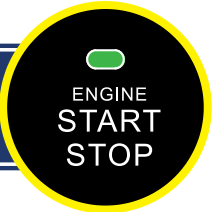

WGen7500DF

Dual Fuel Portable Generator

GASOLINE: 7500 Running Watts | 9500 Peak Watts

PROPANE: 6750 Running Watts | 8550 Peak Watts



⚠ WARNING

Operating, servicing and maintaining this equipment can expose you to chemicals including engine exhaust, carbon monoxide, phthalates, and lead, which are known to the State of California to cause cancer and birth defects or other reproductive harm. To minimize exposure, avoid breathing exhaust, do not idle the engine except as necessary, service your equipment in a well-ventilated area and wear gloves or wash your hands frequently when servicing your equipment. For more information go to www.P65Warnings.ca.gov.

DISCLAIMERS:

All information, illustrations and specifications in this manual are based on the latest information available at the time of publishing. The illustrations used in this manual are intended as representative reference views only. Moreover, because of our continuous product improvement policy, we may modify information, illustrations and/or specifications to explain and/or exemplify a product, service or maintenance improvement. We reserve the right to make any change at any time without notice. Some images may vary depending upon which model is shown.

ALL RIGHTS RESERVED:

No part of this publication may be reproduced or used in any form by any means – graphic, electronic or mechanical, including photocopying, recording, taping or information storage and retrieval systems – without the written permission of MWE Investments LLC.

⚠ DANGER



This manual contains important instructions for operating this generator. For your safety and the safety of others, be sure to read this manual thoroughly before operating the generator. Failure to properly follow all instructions and precautions can cause you and others to be seriously hurt or killed.

WGen7500DF TECHNICAL SPECIFICATIONS

Model Number	Running Watts	Peak Watts	Fuel Tank Size (G)	Rated Speed (RPM)	Ignition Type	Spark plug	Engine Disp (cc)	Stroke X Bore	Oil Capacity (L)	Oil Type
WGen7500DF	Gas: 7500 Propane: 6750	Gas: 9500 Propane: 8550	6.6 Gallons	3600	TCI	F7TC	420cc	66X90	1.1	10W30

NOTICE

Even with a carburetor modification, engine horsepower will decrease about 3.5% for each 300 meter (1,000 foot) increase in altitude. The effect of altitude on horsepower will be greater if no carburetor modification is made. A decrease in engine horsepower will decrease the power output of the generator. Contact our service team to order altitude kits.

FOR YOUR RECORDS:

Date of Purchase:	
Generator Model Number:	
Purchased from Store/Dealer:	
Generator Serial Number:	

HAVE QUESTIONS? Email us at service@wpowerreq.com or call 1-855-944-3571

IMPORTANT: KEEP YOUR PURCHASE RECEIPT TO ENSURE TROUBLE-FREE WARRANTY COVERAGE.

PRODUCT REGISTRATION

To ensure trouble-free warranty coverage, it is important you register your Westinghouse generator. You can register your generator by either:

1. Filling in the product registration form below and mailing to:

Product Registration
 MWE Investments LLC
 777 Manor Park Drive
 Columbus, Ohio 43228

2. Registering your product Online at wpowereq.com/register
 To register your generator you will need to locate the serial number:

WHERE IS MY SERIAL NUMBER?

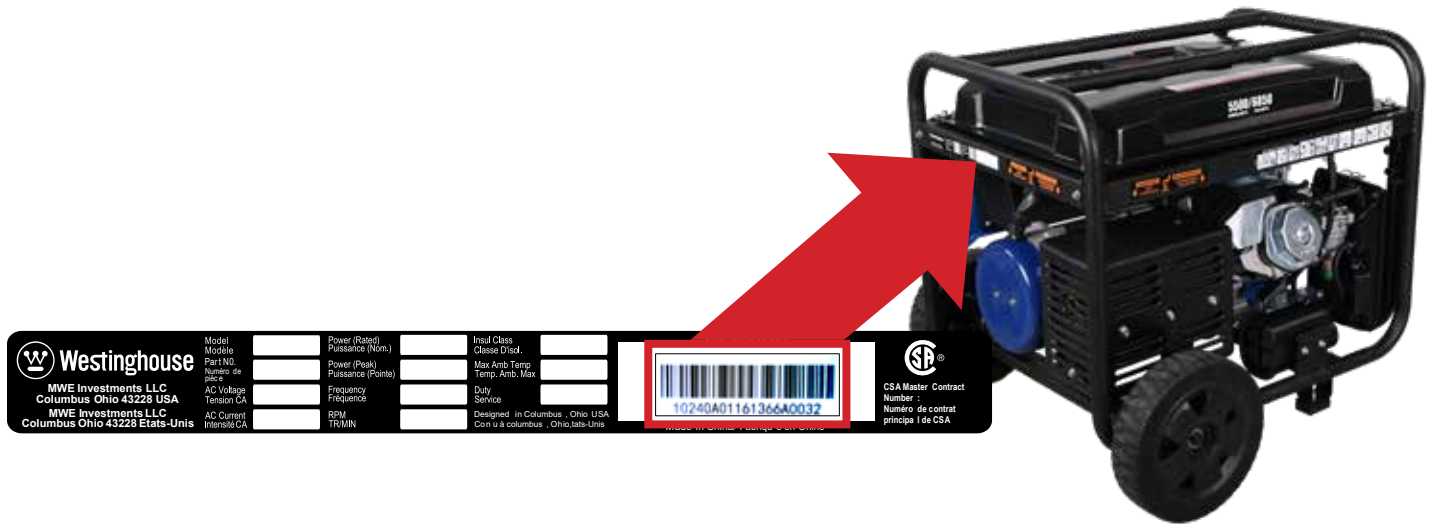

WESTINGHOUSE PRODUCT REGISTRATION FORM

PERSONAL INFORMATION

GENERATOR INFORMATION

First Name: _____ Model Number: _____

Last Name: _____ Serial Number: _____

Street Address: _____ Date Purchased: _____

Street Address: _____ Purchased From: _____

City, State, ZIP: _____

Country: _____

Phone Number: _____

E-Mail: _____



TABLE OF CONTENTS

WGEN7500DF TECHNICAL SPECIFICATIONS	2	MAINTENANCE	24
PRODUCT REGISTRATION	3	Maintenance Schedule	24
For Your Records:	3	Cleaning Spark Arrestor	25
Product Registration	3	Draining Carburetor Float Bowl	25
Product Registration Form	3	Engine Oil Maintenance	26
SAFETY	5	Engine Oil Specification	26
Safety Definitions	5	Checking Engine Oil	26
Safety Symbol Definitions	5	Adding Engine Oil	26
General Safety Rules	6	Changing Engine Oil	27
Safety Labels and Decals	7	Air Filter Maintenance	27
Fuel Safety	9	Cleaning the Air Filter	27
UNPACKING	10	Spark Plug Maintenance	28
What Comes in the Box	10	Checking and Adjusting Valve Lash	29
Wheel Kit Accessories Box	10	Testing GFCI Outlets	29
ASSEMBLY	11	Battery Service	29
Installing Wheels and Feet	11	Battery Replacement	30
Installing the Battery	12	Cleaning the Generator	30
FEATURES	13	Storage	30
Generator Features	13	TROUBLE SHOOTING	31
Control Panel Features	15	SCHEMATICS	33
OPERATION	16	WGen7500DF Schematic	33
Before Starting the Generator	16	EXPLODED AND ENGINE VIEWS	34
Location Selection	16	WGen7500DF Exploded View	34
Grounding the Generator	16	WGen7500DF Engine View	36
High Altitude Operation/Conversion Kits	16		
Power Cord	17		
Using Extension Cords	17		
Using Westinghouse Power Cord	17		
Transfer Switch Connections	18		
Engine Fluids and Fuel	19		
Adding Gasoline to the Fuel Tank	19		
Connecting the LPG/Propane Tank	19		
Connecting to large LPG/Propane Tank	20		
Switching Fuel Sources	20		
Programming Remote Start Fob	21		
Starting the Generator	22		
Starting on Gasoline	22		
Starting on Propane	22		
Electric Start	22		
Manual Start	23		
Stopping the Generator	23		
Normal Operation	23		
During an Emergency	23		

SAFETY

SAFETY DEFINITIONS

The words DANGER, WARNING, CAUTION and NOTICE are used throughout this manual to highlight important information. Be certain that the meanings of these alerts are known to all who work on or near the equipment.



This safety alert symbol appears with most safety statements. It means attention, become alert, your safety is involved! Please read and abide by the message that follows the safety alerts symbol.

DANGER

Indicates a hazardous situation which, if not avoided, *will* result in death or serious injury.

WARNING

Indicates a hazardous situation which, if not avoided, *could* result in death or serious injury.

CAUTION

Indicates a hazardous situation which, if not avoided, *could* result in minor or moderate injury.

NOTICE

Indicates a situation which can cause damage to the generator, personal property and/or the environment, or cause the equipment to operate improperly.

NOTE: Indicates a procedure, practice or condition that should be followed in order for the generator to function in the manner intended.

SAFETY SYMBOL DEFINITIONS

Symbol	Description
	Safety Alert Symbol
	Asphyxiation Hazard
	Burn Hazard
	Burst/Pressure Hazard
	Don't leave tools in the area
	Electrical Shock Hazard
	Explosion Hazard
	Fire Hazard
	Lifting Hazard
	Pinch-Point Hazard
	Read Manufacturer's Instructions
	Read Safety Messages Before Proceeding
	Wear Personal Protective Equipment (PPE)

SAFETY

GENERAL SAFETY RULES

DANGER



Never use the generator in a location that is wet or damp. Never expose the generator to rain, snow, water spray or standing water while in use. Protect the generator from all hazardous weather conditions. Moisture or ice can cause a short circuit or other malfunction in the electrical circuit.



Never operate the generator in an enclosed area. Engine exhaust contains carbon monoxide. Only operate the generator outside and away from windows, doors and vents.

WARNING



Voltage produced by the generator could result in death or serious injury.

- Never operate the generator in rain or a flood plain unless proper precautions are taken to avoid being subject to rain or a flood.
- Never use worn or damaged extension cords.
- Always have a licensed electrician connect the generator to the utility circuit.
- Never touch an operating generator if the generator is wet or if you have wet hands.
- Never operate the generator in highly conductive areas such as around metal decking or steel works.
- Always use grounded extension cords. Always use three-wire or double-insulated power tools.
- Never touch live terminals or bare wires while the generator is operating.
- Be sure the generator is properly grounded before operating.

WARNING



Gasoline and gasoline vapors are extremely flammable and explosive under certain conditions.



- Always refuel the generator outdoors, in a well-ventilated area.
- Never remove the fuel cap with the engine running.
- Never refuel the generator while the engine is running. Always turn engine off and allow the generator to cool before refueling.
- Only fill fuel tank with gasoline.
- Keep sparks, open flames or other form of ignition (such as match, cigarette, static electric source) away when refueling.
- Never overfill the fuel tank. Leave room for fuel to expand. Overfilling the fuel tank can result in a sudden overflow of gasoline and result in spilled gasoline coming in contact with HOT surfaces. Spilled fuel can ignite. If fuel is spilled on the generator, wipe up any spills immediately. Dispose of rag properly. Allow area of spilled fuel to dry before operating the generator.
- Wear eye protection while refueling.
- Never use gasoline as a cleaning agent.
- Store any containers containing gasoline in a well-ventilated area, away from any combustibles or source of ignition.
- Check for fuel leaks after refueling. Never operate the engine if a fuel leak is discovered.

WARNING



Never operate the generator if powered items overheat, electrical output drops, there is sparking, flames or smoke coming from the generator, or if the receptacles are damaged.



Never use the generator to power medical support equipment.



Always remove any tools or other service equipment used during maintenance from the generator before operating.

NOTICE

Never modify the generator.

Never operate the generator if it vibrates at high levels, if engine speed changes greatly or if the engine misfires often.

Always disconnect tools or appliances from the generator before starting.

SAFETY

SAFETY LABELS AND DECALS

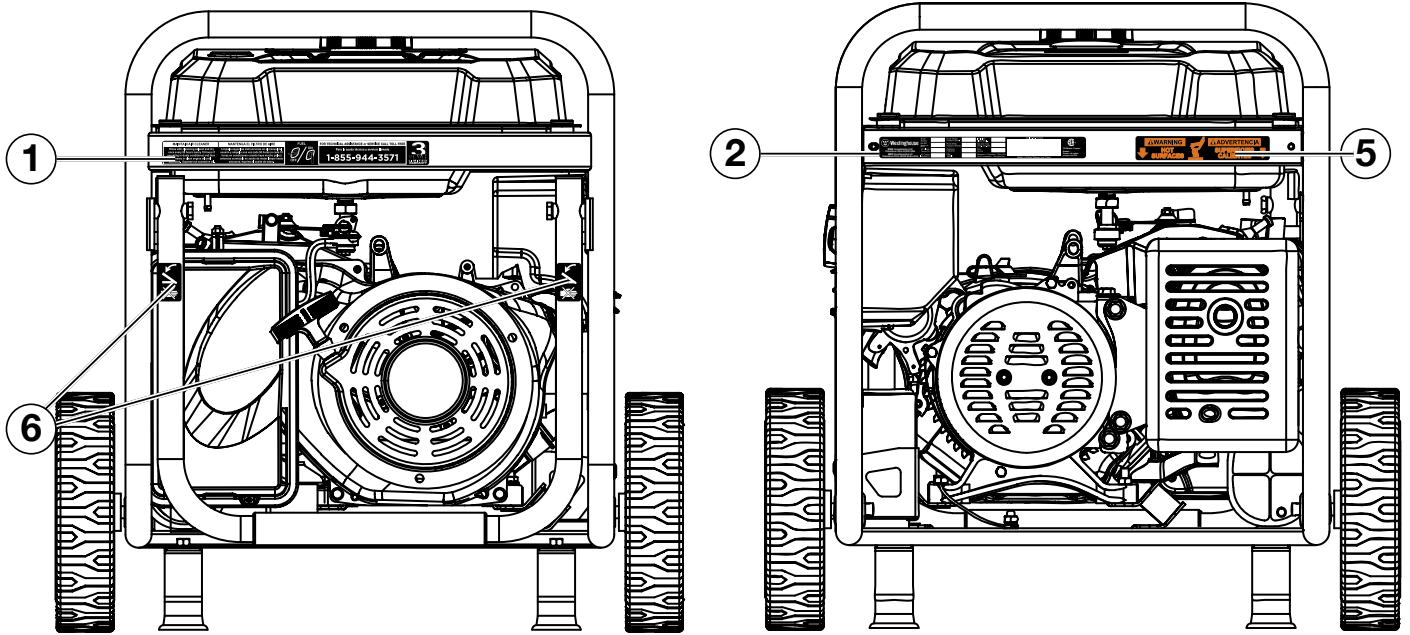

1	MAINTAIN AIR CLEANER Rinse with cleansing solvent and dry once every 50 hours (every 10 hours if operating in dusty conditions) and then immerse in clean engine oil until saturated. Squeeze out excessive oil.	MANTENGA EL FILTRO DE AIRE Limpielo según las instrucciones en el manual del usuario y séquelo una vez cada 50 horas (o cada 10 horas en condiciones cuando haya mucho polvo) entonces sumérgalo en aceite de motor limpio hasta saturarse, exprima el aceite de sobra.	FUEL 	FOR TECHNICAL ASSISTANCE or SERVICE CALL TOLL FREE Para la ayuda técnica y servicio llamada 1-855-944-3571	3 YEAR LIMITED WARRANTY
----------	----------------------------------------------------------------------------------------------------------------------------------------------------------------------------------------------------------------------------	-----------------------------------------------------------------------------------------------------------------------------------------------------------------------------------------------------------------------------------------------------------------------------------	-----------------	--------------------------------------------------------------------------------------------------------------------------------	--------------------------------

2	Westinghouse MWE Investments LLC Columbus Ohio 43228 USA MWE Investments LLC Columbus Ohio 43228 États-Unis	Model / Modèle: _____ Part No. / Numéro de pièce: _____ AC Voltage / Tension CA: _____ AC Current / Intensité CA: _____	Power (Rated) / Puissance (Nom.): _____ Power (Peak) / Puissance (Pointe): _____ Frequency / Fréquence: _____ RPM / TR/MIN: _____	Inul Class / Classe Dist.: _____ Max Amb Temp / Temp. Amb. Max.: _____ Duty / Service: _____ Designed in Columbus, Ohio USA / Conçu à Columbus, Ohio États-Unis	Serial No./No. De Série: _____ CSA Master Contract Number / Numéro de contrat principal de CSA: _____ Made in China / Fabriqué en Chine
----------	--------------------------------------------------------------------------------------------------------------------------------	----------------------------------------------------------------------------------------------------------------------------------	--------------------------------------------------------------------------------------------------------------------------------------------	--------------------------------------------------------------------------------------------------------------------------------------------------------------------------	-----------------------------------------------------------------------------------------------------------------------------------------------

4	⚠ DANGER	⚠ PELIGRO
Read owners manual before operating generator on LPG/propane. LPG/Propane is highly flammable. Leaking LP-gas can cause a fire or explosion if ignited. If you smell propane while you are operating unit, immediately shut off propane valve. Keep propane tank away from exhaust.	Lea el manual del propietario antes de operar el generador con GLP / propano. GLP / propano es altamente inflamable. La fuga de gas LP puede causar un incendio o una explosión si se enciende. Si huele a propano mientras está operando la unidad, apague inmediatamente la válvula de propano. Mantenga el tanque de propano lejos del escape.	

5	⚠ WARNING HOT SURFACES	⚠ ADVERTENCIA SUPERFICIES CALIENTES
----------	-----------------------------------------	------------------------------------------------------

6	7

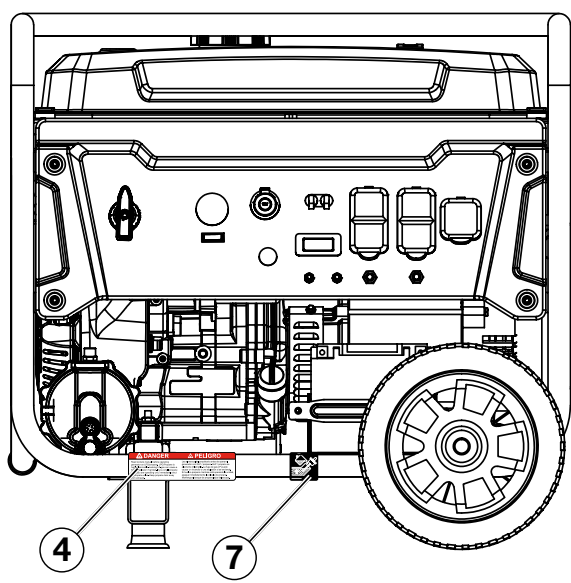

SAFETY

SAFETY LABELS AND DECALS

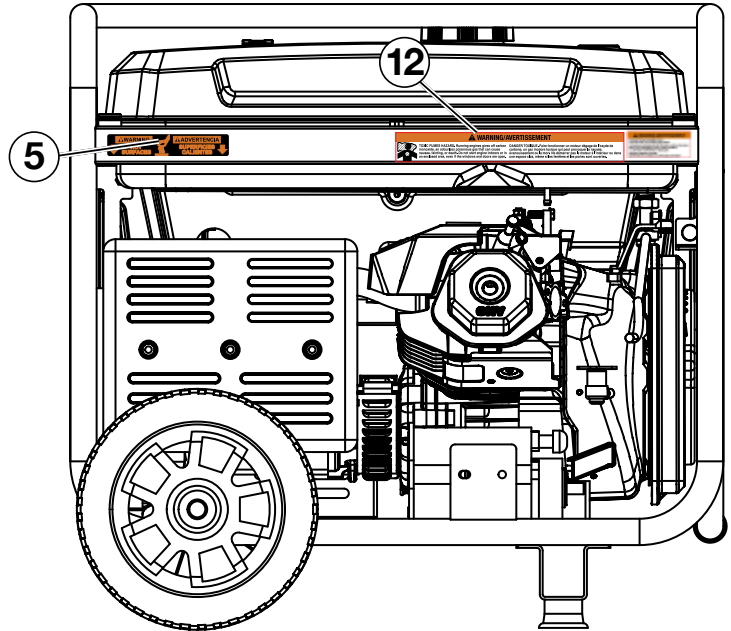
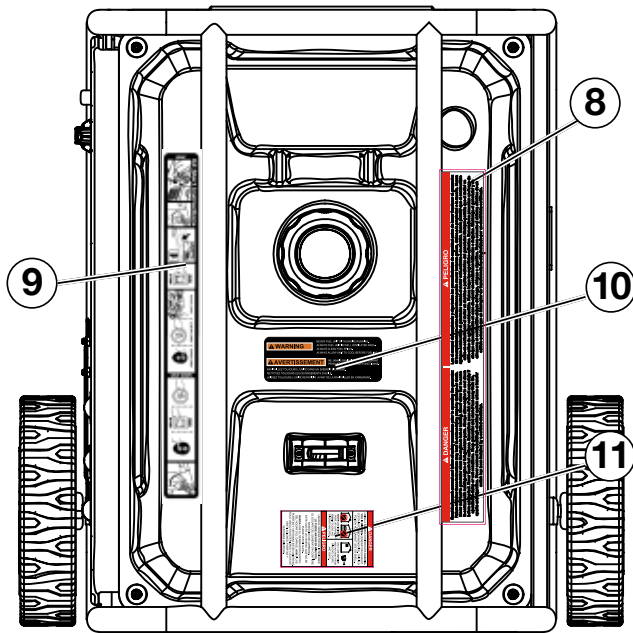

8	⚠ DANGER	⚠ PELIGRO
	<p>Read the owner's manual and follow all safety procedures prior to operating the generator. Failure to follow these instructions may lead to serious injury, property damage or death. Never add fuel to generator when the engine is hot or running. Never allow fuel to come in contact with running engine or hot generator parts. Always allow engine to cool down before adding fuel. Never touch hot surfaces. Generators pose risk of shock especially if operated in damp or wet conditions. Keep generator and stored fuel away from fire, sparks and cigarettes. Never connect to a building's electrical system unless a transfer switch has been installed by a certified electrician.</p>	<p>Lea el manual del propietario y siga todos los procedimientos de seguridad antes de hacer funcionar el generador. El incumplimiento de estas instrucciones puede causar lesiones graves, daños a la propiedad o la muerte. Nunca agregue combustible al generador cuando el motor está caliente o en marcha. Nunca permita que el combustible entre en contacto con el motor en marcha o partes calientes del generador. Siempre permita que el motor se enfríe antes de agregar combustible. Nunca toque las superficies calientes. Generadores presentan un riesgo de choque especialmente en caso de operar en condiciones húmedas o mojadas. Mantenga el generador y su almacena el combustible alejado del fuego, chispas o cigarrillos. Nunca conecte al sistema eléctrico de un edificio a menos que un interruptor de transferencia ha sido instalado por un electricista certificado.</p>



10	<p>⚠ WARNING</p> <p>NEVER FUEL UNIT WITH ENGINE RUNNING. ALWAYS FUEL UNIT IN WELL VENTILATED AREA. ALWAYS CLEAN FUEL SPILLS. ALWAYS ALLOW UNIT TO COOL BEFORE FUELING.</p> <p>⚠ AVERTISSEMENT</p> <p>NE JAMAIS RAVITAILLER EN CARBURANT PENDANT QUE LE MOTEUR FONCTIONNE. RAVITAILLER TOUJOURS L'UNITÉ DANS UN ENDROIT BIEN AÉRÉ. NETTOYEZ TOUJOURS LES DÉVERSEMENTS D'HUILE. LAISSEZ TOUJOURS L'UNITÉ REFRROIDIR AVANT DE LA RAVITAILLER EN CARBURANT.</p>
-----------	---------------------------------------------------------------------------------------------------------------------------------------------------------------------------------------------------------------------------------------------------------------------------------------------------------------------------------------------------------------------------------------------------------------------------------------------------------------------------

11	⚠ DANGER	⚠ PELIGRO
	<p>USING A GENERATOR INDOORS CAN KILL YOU IN MINUTES. GENERATOR EXHAUST CONTAINS CARBON MONOXIDE. THIS IS A POISON YOU CANNOT SEE OR SMELL.</p> <p> NEVER USE INSIDE A HOME OR GARAGE, EVEN IF DOORS AND WINDOWS ARE OPEN.</p> <p> ONLY USE OUTSIDE AND FAR AWAY FROM WINDOWS, DOORS, AND VENTS.</p>	<p>USAR EL GENERADOR EN INTERIORES LO PUEDE MATAR EN MINUTOS. EL ESCAPE DEL GENERADOR CONTIENE MONÓXIDO DE CARBONO. ESTE GAS ES UN VENENO QUE NO SE PUEDE VER NI OLER.</p> <p>NUNCA USE EL GENERADOR DENTRO DEL HOGAR O EL GARAJE, AUN SI LAS PUERTAS Y VENTANAS ESTÁN ABIERTAS. SOLO USELO EN EXTERIORES Y LEJOS DE VENTILACIONES, PUERTAS Y VENTANAS ABIERTAS.</p>

12	⚠ WARNING/AVERTISSEMENT	⚠ WARNING/AVERTISSEMENT
	<p> TOXIC FUMES HAZARD. Running engines gives off carbon monoxide, an odorless poisonous gas that can cause nausea, fainting, or death. Do not start engine indoors or in an enclosed area, even if the windows and doors are open.</p> <p>DANGER TOXIQUE. Faire fonctionner un moteur dégage de l'oxyde de carbone, un gaz inodore toxique qui peut provoquer la nausée, évanouissement ou la mort. Ne démarrer pas le moteur à l'intérieur ou dans une espace clos, même si les fenêtres et les portes sont ouvertes.</p>	<p>FOR ELECTRICAL EQUIPMENT ONLY POUR MATÉRIEL ÉLECTRIQUE SEULEMENT</p> <p>FOR USE IN A WEATHER-PROTECTED WELL VENTILATED AREA EMPLOYEZ SÉVÉMENT DANS UN ENDROIT BIEN AÉRÉ ET PROTÉGÉ DES INTÉMPÉRIES</p> <p>NEUTRAL BONDED TO FRAME NEUTRE MIS À LA MASSE À LA CARCASSE DU MOTEUR</p>

SAFETY

FUEL SAFETY

DANGER



Gasoline and liquid petroleum gas (LPG) are highly explosive and flammable. Explosions and fire can cause severe burns or death.

Gasoline and gasoline vapor (Gas)

- Gasoline is highly flammable and explosive.
- Gas expands and contracts with different temperatures.
- In case of a gas fire, do not attempt to extinguish the flame if the fuel shutoff valve is in the on position. Introducing an extinguisher to a generator with an open fuel valve could create an explosion hazard.
- Gas has a distinctive odor, this will help detect potential leaks quickly.
- Gas vapors can cause a fire if ignited.
- Gasoline is a skin irritant and needs to be cleaned up immediately if it comes in contact with the skin.

Liquid Petroleum Gas (Propane/LPG)

- LPG/Propane is highly flammable and explosive.
- Flammable gas under pressure can cause a fire or explosion if ignited.
- LPG/Propane can settle in low places because it is heavier than air.
- LPG/Propane has a distinctive odor added to help detect potential leaks.
- Always keep LPG/Propane tank in an upright position.
- When exchanging LPG/Propane tanks, be sure the tank value is the same type.
- In case of a LPG/Propane fire, do not attempt to extinguish unless the fuel supply can be shut off.
- LPG/Propane will burn the skin. Prevent skin contact at all times.

WARNING



Never use a gas container, LPG connector hose, LPG tank or any other fuel item that appears to be damaged.

When starting generator:

- Make sure that the gas cap, air filter, spark plug, fuel lines and exhaust system are properly in place.
- If you spill any gasoline on the tank, allow it to fully evaporate before operating.
- Make sure the generator and propane tank are on a flat surface before operating.
- If there is a propane odor do not start the unit because there may be a potential leak.
- Never place propane tank near engine exhaust.

When transporting or servicing the generator:

- Make certain the fuel shutoff valve is off and the fuel tank is empty.
- Make sure the LPG tank and LPG hose is not attached to the generator.
- Disconnect the spark plug wire.

When storing the generator:

- Store away from sparks, open flames, pilot lights, heat and other sources of ignition.
- Do not store gas or LPG tank near furnaces, water heaters or any other appliances that produce heat or have automatic ignitions.

CAUTION



Only use approved LPG tanks with OPD (overfilling prevention device) valve. Always keep the tank in a vertical position with the valve on top and installed at ground level on a flat surface. Do not allow tanks to be around any heat source and make sure it is not exposed to the sun, rain and dust. When transporting and storing, turn off the tank valve and fuel valve, and disconnect the tank. Make sure to always cover the generator and tank outlet with protective plastic caps.

CAUTION



Do not allow children to tamper or play with the propane tank or hose connections.

WARNING



If there is a strong smell of propane while operating the generator close the valve on the propane tank immediately. Once the propane is off, use soapy water to check for leaks on the hose and connections on the tank valve and the generator. Do not smoke or light a cigarette or check for leaks using any open flame source such as a match or lighter. If a leak is found contact a qualified technician to inspect and repair the LPG system before using the generator.

UNPACKING

⚠ CAUTION



Always have assistance when lifting the generator. The generator is heavy; lifting it could cause bodily harm.



Avoid cutting on or near staples to prevent personal injury.

Tools required – box cutter or similar device.

1. Carefully cut the packing tape on top of the carton.
2. Fold back top flaps to reveal the manual.
3. Remove the Wheel Kit Accessories cardboard box.
4. Carefully cut two sides of the carton to remove the generator.
5. Remove LPG hose from under gas tank.

WHAT COMES IN THE BOX

Manual
 Quick Start Guide/Maintenance Schedule
 LPG Hose (1)
 Wireless Remote Starter (1)
 11W Battery Charger, (14V .8A output) (1)
 1.1 Liter Bottle of SAE 10W30 Oil (1)
 Spark Plug Socket Wrench (1)
 Wheel Kit Accessories Box
 Funnel (1)

WHEEL KIT ACCESSORIES BOX

Open the Wheel Kit Accessories box and verify the contents against the list right. If any parts are missing, contact our service team at service@wpowerreq.com or call 1-855-944-3571.

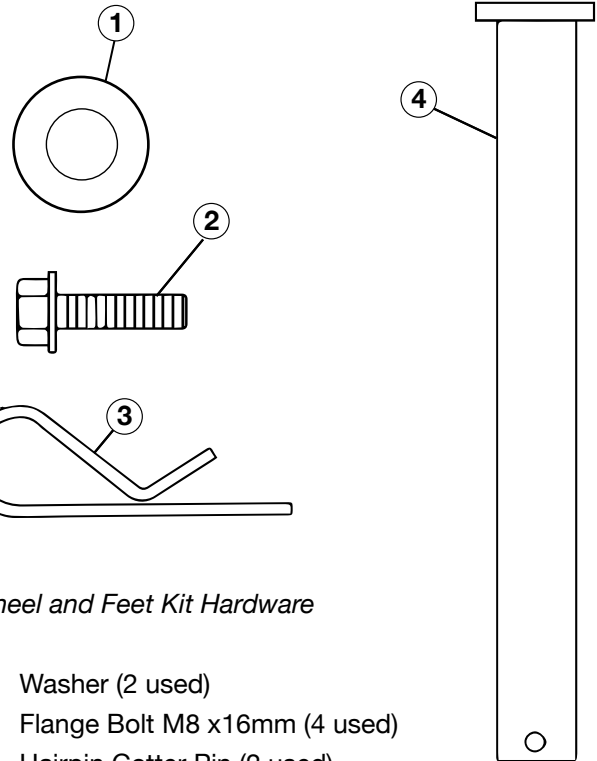

Wheel and Feet Kit Hardware

1. Washer (2 used)
2. Flange Bolt M8 x16mm (4 used)
3. Hairpin Cotter Pin (2 used)
4. Wheel Axle Pin (2)



LPG hose is shipped under fuel tank on opposite side of generator

ASSEMBLY

INSTALLING WHEELS AND FEET



BEFORE ASSEMBLING THE GENERATOR, REVIEW THE SAFETY SECTION STARTING ON PAGE 5.

⚠ CAUTION



Never lift the generator without assistance. The generator is heavy and lifting without assistance could result in personal injury.



Never use the handles as a lifting point to support the entire weight of the generator. Only use the handles to move the generator by lifting the handles and using the wheels to move the generator.



Use caution when collapsing the handles. Hands and fingers could get caught and pinched.

NOTICE

Assembling the generator will require lifting the unit on one side. Make sure all engine oil and fuel are drained from the unit prior to assembling. Once assembled, the wheel kit is not intended for on-road use. The wheel kit is designed for use on this generator only.

INSTALLING FEET TO FRAME

1. Place generator on a flat surface.
2. Place a piece of cardboard or other soft material to tip the generator onto, to protect the frame paint and prevent the generator from sliding. Tip the generator onto the side.
3. Install the mounting foot to the frame using M8 flange bolts.

- 1 - Mounting Feet
- 2 - Flange Bolts M8

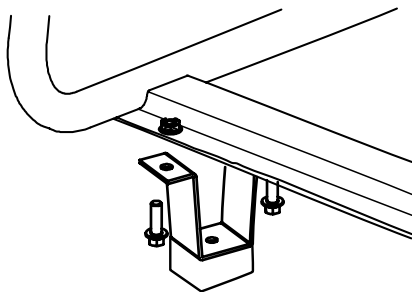

Figure 1 - Assemble Mounting Feet to Frame

INSTALLING WHEELS TO FRAME

1. Insert axle pin through washer and wheel.

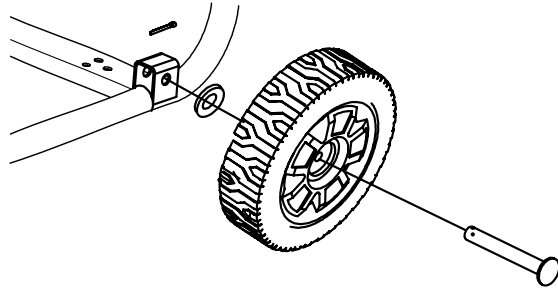

Figure 2 - Wheel Assembly

2. Install the wheel with axle pin through the axle bracket on the frame. The eye of the bolt should be facing toward the inside of the generator.

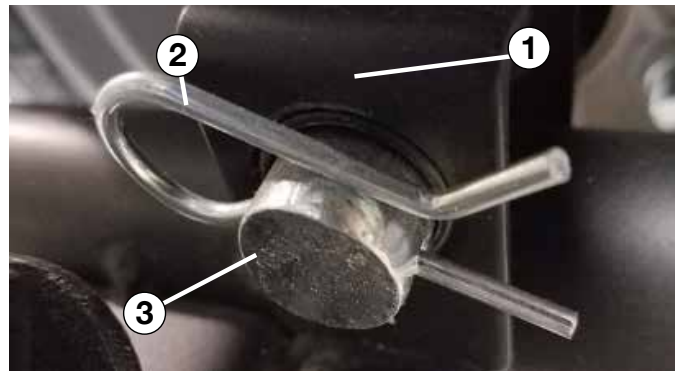

Figure 3 - Assemble Wheel to Frame

3. Install the hairpin cotter through the axle pin to lock it in place.
 - 1 - Axle Bracket
 - 2 - Hairpin Clip
 - 3 - Axle Pin
4. Repeat previous steps on other wheel.

ASSEMBLY

CONNECTING THE BATTERY

⚠ WARNING



To avoid electric shock:

- ALWAYS connect the positive (+) battery cable (red boot) first when connecting battery cables.
- ALWAYS disconnect the negative (-) battery cable (black boot) first when disconnecting battery cables.
- NEVER connect the negative (-) battery cable (black boot) to the positive (+) post on the battery.
- NEVER connect the positive (+) battery cable (red boot) to the negative (-) post on the battery.
- NEVER touch both battery posts simultaneously.
- NEVER place a metal tool across both battery posts.
- ALWAYS use insulated or nonconducting tools when installing the battery.

1. Always make sure to attach the positive (+) battery cable first (1) and then the negative (-) cable second (2) (see Figure 4).



Figure 4 - Battery Connection Order

- 1 - Positive (+) Battery Cable (Red)
- 2 - Negative (-) Battery Cable (Black)

2. Securely tighten the positive (+) battery cable (red boot) to the positive (+) battery post. Make sure boot is over battery post.

3. Carefully remove the protective wrapping around the lug of the negative (-) battery cable (black boot).
4. Locate the black negative (-) cable attached to the alternator case, route it to the negative (-) battery post. See Figure 5 below for location of negative (-) cable.



Figure 5 - Locating Negative (-) Cable

5. Pull back the black boot and securely attach the negative (-) battery cable (black boot) to the negative (-) battery post as shown in Figure 4. Replace the black boot so it protects the cable lug and battery post.

NOTICE

The electric start generator is equipped with a battery charging feature. Once the engine is running, a small charge is supplied to the battery via the battery cables and will slowly recharge the battery.

FEATURES



① **Fuel Selector Switch:** Used to select and turn on gasoline or propane fuel source.

② **Push Button Electric Start:** Starts and stops the engine.

③ **Engine Control Switch/Battery Disconnect:** Allows fuel to flow to engine and energizes the ignition system. Also, disconnects battery power when in **STOP** position.

④ **Fuel Cap:** Close until clicking sound is heard.

⑤ **Control Panel:** Contains the circuit breakers and outlets.

⑥ **Battery:** Included for electric start models.

⑦ **Oil Fill Plug/Dipstick:** Must be removed to add and check oil.

⑧ **Oil Drain Plug:** Must be removed to drain engine oil.

⑨ **Propane Hook Up:** Hook up your propane tank with the LPG hose provided to this inlet.

⑩ **Never Flat Wheels:** For easy portability

⑪ **Auto Choke:** Battery must be hooked up for auto choke to work properly. You can manually adjust the choke if the battery is not connected.

⑫ **Gas Fuel Shut Off Valve:** Controls the flow of gas to the engine.

⑬ **Single Piece Handle:** Includes rubber grip. Allows you to easily push or pull unit with one hand.

FEATURES



- ⑭ **Fuel Gauge:** Indicates fuel level.
- ⑮ **Spark Plug Boot (Wire):** Must be removed when servicing the engine or the spark plug.
- ⑯ **CARB Canister:** Required for models sold into and used in California.
- ⑰ **Muffler and Spark Arrester:** Avoid contact until engine is cooled down. Spark arrester prevents sparks from exiting the muffler. It must be removed for servicing.
- ⑱ **Alternator Cover:** Gain access to alternator wiring.
- ⑲ **Remote Start Pairing Button:** Initiates the remote key fob pairing function.

FEATURES

CONTROL PANEL FEATURES

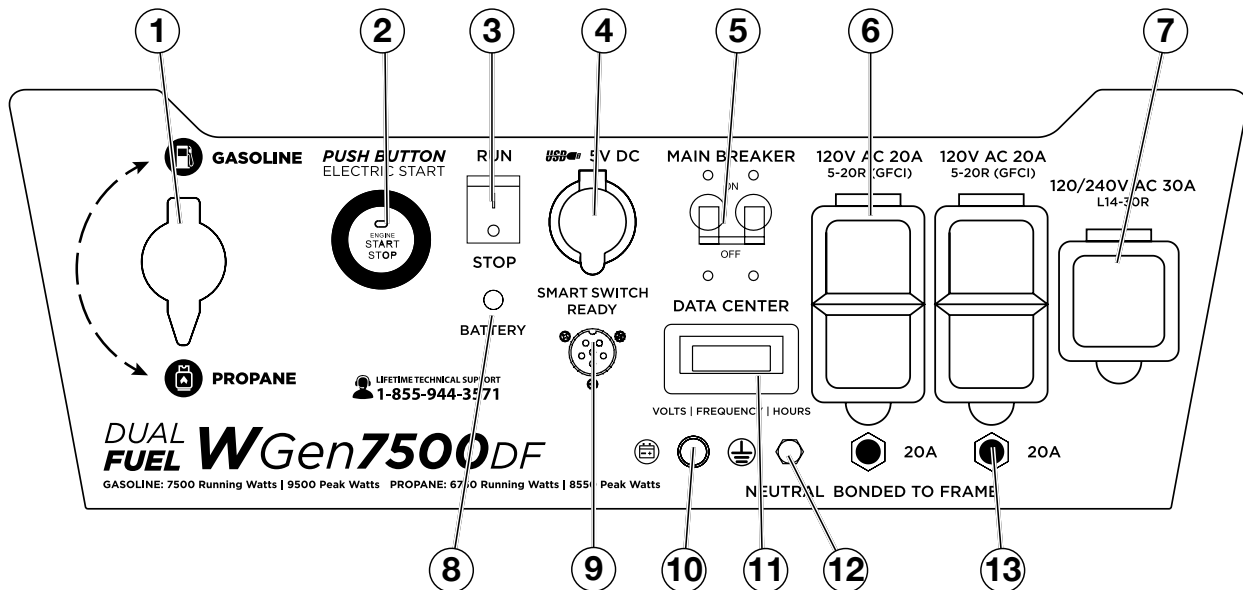

- ① **Fuel Selector Switch:** Select and turn on gas or propane.
- ② **Push Start Button:**
 - Push for 1 second to automatically start the engine.
 - Push for 1 second again to stop the engine.
- ③ **Engine Control Switch/Battery Disconnect:** Switch to **STOP** to stop the engine. When in **STOP** position it prevents the unit from drawing power from the battery. Switch to **RUN** before starting engine.
- ④ **5V USB Ports:** 5V DC that come in 1 amp and 2.1 amps.
- ⑤ **Main Circuit Breaker:** The main circuit breaker controls total output of all outlets to protect the generator.
- ⑥ **120-Volt, 20-Amp Duplex GFCI Outlets (NEMA 5-20R):** Each outlet is capable of carrying a maximum of 20 amps on a single receptacle or a combination of both receptacles.
- ⑦ **120/240-Volt, 30-Amp Twist Lock Outlet (NEMA L14-30R):** Outlet can supply either 120V or 240V output.
- ⑧ **Battery Indicator Light:** When light is illuminated, the battery is on.
- ⑨ **Smart Switch Outlet:** Connects the Westinghouse ST Switch (sold separately) to the control panel.
- ⑩ **Battery Charge Port:** Used to charge the battery when the unit is off (charger included).
- ⑪ **Data Center:** The VFT Meter is an LED display that will rotate through volts, frequency, and lifetime run hours. You can press the **MODE** button to cycle through the different displays.

The frequency and voltage can vary +/- 5% and still be within tolerance.

U250	Voltage
F-60	Frequency in hertz
00:07	Lifetime run hours
- ⑫ **Ground Terminal:** The ground terminal is used to ground the generator.
- ⑬ **20-Amp Circuit Breakers:** Each circuit breaker limits the current that can be delivered through the 120-volt duplex outlets to 20amps.

OPERATION



BEFORE STARTING THE GENERATOR





BEFORE STARTING THE GENERATOR, REVIEW SAFETY SECTION STARTING ON PAGE 5.

Location Selection – Before starting the generator, avoid exhaust and location hazards by verifying:

- You have selected a location to operate the generator that is outdoors and well ventilated.
- You have selected a location with a level and solid surface on which to place the generator.
- You have selected a location that is at least 15 feet (4.5m) away from any building, other equipment or combustible material.
- If the generator is located close to a building, make sure it is not located near any windows, doors and/or vents.

⚠ DANGER	
Using a generator indoors CAN KILL YOU IN MINUTES. Generator exhaust contains carbon monoxide. This is a poison you cannot see or smell.	
 NEVER use inside a home or garage, EVEN IF doors and windows are open.	 Only use OUTSIDE and far away from windows, doors, and vents.
Avoid other generator hazards. READ MANUAL BEFORE USE.	

⚠ WARNING	
	Always operate the generator on a level surface. Placing the generator on non level surfaces can cause the generator to tip over, causing fuel and oil to spill. Spilled fuel can ignite if it comes in contact with an ignition source such as a very hot surface.
	Do not operate a device plugged into the USB ports. Prolonged exposure to engine exhaust can cause serious injury or death. While charging a device do not place on the exhaust side of the generator. Extreme heat caused by exhaust can damage the device, and cause a potential fire hazard.

NOTICE	
Only operate the generator on a solid, level surface. Operating the generator on a surface with loose material such as sand or grass clippings can cause debris to be ingested by the generator that could:	
<ul style="list-style-type: none">• Block cooling vents• Block air intake system	

Weather – Never operate your generator outdoors during rain, snow or any combination of weather conditions that could lead to moisture collecting on, in or around the generator.

Dry Surface – Always operate the generator on a dry surface free of any moisture.

No Connected Loads – Make sure the generator has no connected loads before starting it. To ensure there are no connected loads, unplug any electrical extension cords that are plugged into the control panel receptacles.

NOTICE	
Starting the generator with loads already applied to it could result in damage to any appliance being powered off the generator during the brief start-up period.	

Grounding the Generator – The National Electric Code (NEC), as well as many local electrical codes, may require the generator to be connected to earth ground. The most common application that requires a ground rod is when you are using the generator as a separately derived system to provide back up power to your house. Typically this is when a transfer switch has a switched neutral.

As the generator application has many variables that cannot be determined by the manufacturer of the generator, a licensed electrician will need to determine if a grounding rod is needed.

If a licensed electrician has determined the application requires a ground rod, make sure it is connected to earth ground by connecting the ground terminal on the control panel to earth ground using copper wire (minimum 10 AWG). Consult a qualified electrician for local grounding requirements.

Neutral Bonded: There is a permanent conduct between the generator (stator winding) and the frame.

⚠ WARNING	
	Be sure the generator is properly connected to earth ground before operating. The generator must be grounded to prevent electrical shock due to faulty appliances.

High Altitude Operation

Engine power is reduced the higher you operate above sea level. Output will be reduced approximately 3.5% for every 1000ft of increased altitude from sea level. This is a natural occurrence and cannot be adjusted by engine. Increased exhaust emissions can also result due to increased fuel mixture. Other issues include hard starting, increased fuel consumption and spark plug fouling. Contact our service team **1-855-944-3571** for altitude part kits.

High Altitude Carburetor Kit Part Number: 140545
High Altitude DF Regulator Part Number: 140547

OPERATION

POWERCORD

Using Extension Cords

Westinghouse Portable Power assumes no responsibility for the content within this table. The use of this table is the responsibility of the user only. This table is intended for reference only. The results produced by using this table are not guaranteed to be correct or applicable in all situations as the type and construction of cords are highly variable. Always check with local regulations and a licensed electrician prior to installing or connecting an electrical appliance

Extension Cord Wire Gauge Size

AMPS	LENGTH OF EXTENSION CORD (ft)								
	10	20	30	40	50	60	80	100	120
5	20	18	16	14	12	12	10	10	8
10	18	16	14	12	12	10	10	8	8
15	16	14	12	12	10	10	8	8	6
20	14	12	12	10	10	8	8	6	6
25	12	12	10	10	8	8	6	6	6
30	12	10	10	8	8	6	6	6	6
35	10	10	8	8	6	6	6	6	6

Using Westinghouse Power Cord

Use the extension cord chart to determine the size of the conductor for extension cord applications. Determine the distance of the generator to the appliance on the top line of the chart. Then select the rated amperage of the generator on the left side of the chart. Where the two meet is the size of the conductor required for the application.

When using the WCG25/WCG20 power cord (sold separate) connect to the 120/240V outlet. The opposite end of the power cord is a fan tail receptacle with 2 green receptacles and 2 red receptacles. Each receptacle is rated at 120 volts AC. To balance the load on the generator's alternator, use the red and green identifiers on the fan tail receptacle. To keep the load balanced, connect the loads so that both color receptacles are used. An example is one in red and one in green. Do not connect 2 in red and none in green, or 2 in green and none in red. If only one color receptacle is used with multiple loads, the alternator may experience an unbalanced load, causing undue vibration to generator.

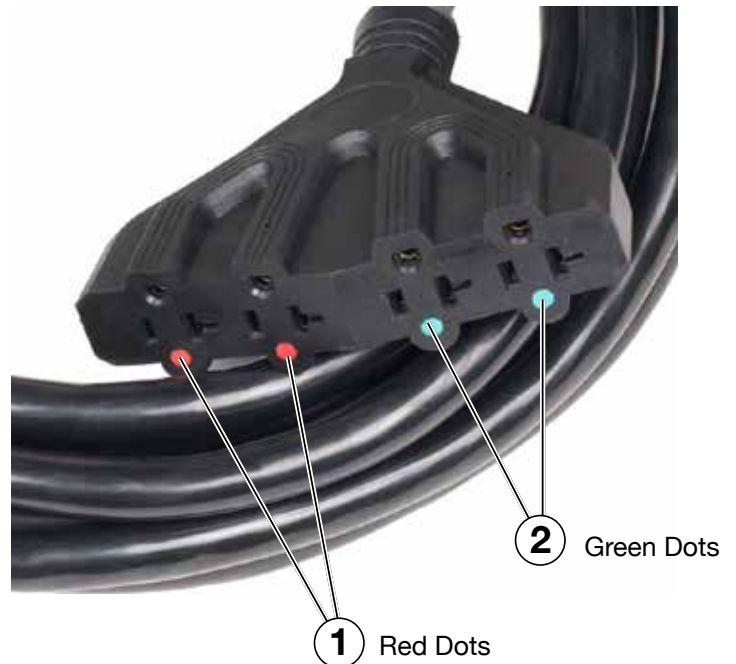

- WCG25/WCG20 Extension Cord

OPERATION

CONNECTING THE GENERATOR TO A BUILDING ELECTRICAL SYSTEM

It is recommended to use a manual transfer switch when connecting directly to a buildings electrical system. Connecting a portable generator to a buildings electrical system must be made in strict compliance with all national and local electrical codes and laws, and be completed by a qualified electrician.

TRANSFER SWITCH CONNECTIONS

The Westinghouse generator is wired with the neutral bonded to ground. If you are connecting your generator to a panel board transfer switch, a licensed electrician will need to consider removing the bonded neutral to ensure proper operation of household GFCI circuits. Begin by removing the alternator cover (18 on page 14). Once the cover is off remove the nut that holds the bonded ground jumper wire (see “2” in Figure 6). Once the nut is removed take the bonded jumper wire off and re-secure the nut. Next remove the screw holding the neutral ground wire (see “1” in Figure 6). Attach the bonded jumper wire (2) to the neutral ground (1) and tighten the screw.

If the bonded neutral is removed the generator must be relabeled as floating neutral on the control panel.

If your generator is equipped with GFCI receptacles, removing the bonded neutral may not allow proper operation of the GFCI receptacles. Always keep the jumper wire in case it is needed for future use when not connected to a transfer switch.

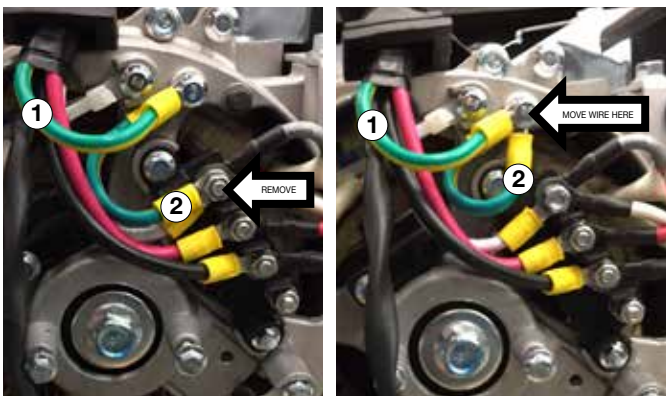

- ① Alternator Neutral Ground Wire (white/Green)
- ② Alternator Bonded Jumper Wire (white/Green)

Figure 6

ADDING / CHECKING ENGINE FLUIDS AND FUEL



BEFORE ADDING/CHECKING ENGINE FLUIDS AND FUEL, REVIEW SAFETY SECTION STARTING ON PAGE 5.

⚠ DANGER



Filling the fuel tank with gasoline while the generator is running can cause gasoline to leak and come in contact with hot surfaces that can ignite the gasoline.

Before starting the generator, always check the level of:

- Engine oil
- Gasoline in the fuel tank

Once the generator is started and the engine gets warm, it is not safe to add gasoline to the fuel tank or engine oil to the engine while the engine is running or the engine and muffler are hot.

CHECKING AND / OR ADDING ENGINE OIL

⚠ WARNING



Internal pressure can build in the engine crankcase while the engine is running. Removing the oil fill plug/ dipstick while the engine is hot can cause extremely hot oil to spray out of the crankcase and can severely burn skin. Allow engine oil to cool for several minutes before removing the oil fill plug/dipstick.

The unit as shipped does not contain oil in the engine. You must add engine oil before starting the generator for the first time. See *Checking Engine Oil* and *Adding Engine Oil* on page 26 for instructions on checking engine oil level and the procedure for adding engine oil.

NOTICE

The engine does not contain engine oil as shipped. Attempting to start the engine can damage engine components. The owner of the generator is responsible to ensure the proper oil level is maintained during the operation of the generator. Failure to maintain the proper oil level can result in engine damage.

NOTICE

During the first five hours of operating the generator make sure to not exceed 50% of the rated running watts until the unit is broken in properly. Make sure to vary to load occasionally to allow stator windings to heat and cool. Adjusting the load will also help seat piston rings. Check oil more often during the first couple times of operating the generator.

NOTICE

Weather will affect engine oil performance. Change the type of engine oil used based on weather conditions to suit the engine needs.

OPERATION

ADDING GASOLINE TO THE FUEL TANK BEFORE ADDING GAS TO THE TANK PLEASE REVIEW FUEL SAFETY SECTION ON PAGE 9



⚠ WARNING	
	Never refuel the generator while the engine is running.
	Always turn the engine off and allow the generator to cool before refueling.

Required Gasoline – Only use gasoline that meets the following requirements:

- Unleaded gasoline only
- Gasoline with maximum 10% ethanol added
- Gasoline with an 87 octane rating or higher

Filling the Fuel Tank – Follow the steps below to fill the fuel tank:

1. Shut off the generator.
2. Allow the generator to cool down so all surface areas of the muffler and engine are cool to the touch.
3. Move the generator to a flat surface.
4. Clean area around the fuel cap.
5. Remove the fuel cap by rotating counterclockwise.
6. Slowly add gasoline into the fuel tank. Be very careful not to overfill the tank. The gasoline level should NOT be higher than the filler neck (see Figure 7).
7. Install the fuel cap by rotating clockwise until you hear a click, indicating the cap is completely installed.

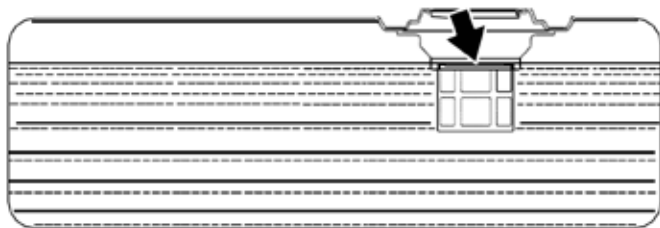

Figure 7 - Maximum Gasoline Fill Level

⚠ CAUTION	
	Avoid prolonged breathing of gasoline vapors.

CONNECTING TO STANDARD LPG/PROPANE TANK BEFORE CONNECTING PROPANE TANK TO THE GENERATOR PLEASE REVIEW FUEL SAFETY SECTION ON PAGE 9



Connecting LPG Tank

1. Make sure the generator is off, on a flat surface in well ventilated area.
2. Make sure propane tank valve is in the off position.
3. Make sure the fuel selector switch on the generator control panel is pointing downward to “Propane”.
4. Remove the plastic cover on the generator propane inlet valve.
5. Using your fingers tighten the LPG hose (included) end below to the generator propane inlet. DO NOT OVERTIGHTEN 35-88 lb-in maximum.

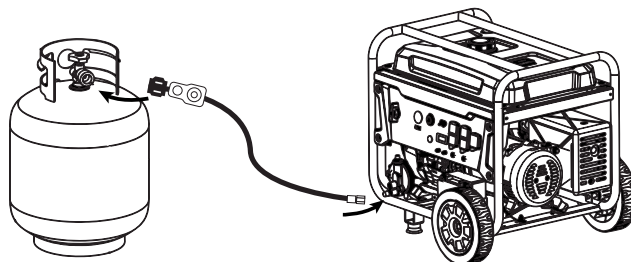

6. Attach the other end of the hose to a tank of LPG/Propane and hand tighten.
7. Check all connections for leaks by wetting the fittings with soapy water. Anywhere that bubbles appear or grow indicates a leak in the connection. If a leak exists at a fitting then turn off the tank valve and tighten the fitting. Turn the gas back on and recheck with soapy water again. If the leak continues or if the leak is not at a fitting then do not use the generator and contact customer service.

NOTICE

- When using standard 20 or 30 pound capacity LPG tanks, make sure they have Type 1, right hand Acme threads.
- Verify the requalification date on the tank has not expired.
- All new tanks must be purged of air and moisture prior to filling. Used tanks that have not been plugged or kept closed must also be purged
- The purging process should be done by a LPG supplier. (Tanks from an exchange supplier should have been purged and filled properly already)
- Always position the tank so the connection between the valve and the gas inlet won't cause sharp bends or kinks in the hose.

⚠ WARNING	
	Do not start generator if you smell propane. This may result in explosion hazard. Do not use provided LPG hose for any other appliances. Always turn off the propane tank and disconnect LPG hose when not in use.

OPERATION

CONNECTING TO LARGE LPG/PROPANE TANK BEFORE CONNECTING PROPANE TANK TO THE GENERATOR PLEASE REVIEW FUEL SAFETY SECTION ON PAGE 9



You can hook up you Duel Fuel Generator to a large home LP tank. It is required that you consult a plumber to properly connect your generator to the tank.

To properly connect with a large propane tank you must first check and confirm the LP fuel pressure at the outlet of the LP tank. The LP fuel pressure should be 14-10" of water column, which is the standard fuel pressure for residential gas fired appliances.

If the LP fuel pressure is within the 14-10" water column range, the primary fuel regulator should be removed from the fuel line components. Then plumb directly from the LP tank to the secondary regulator assembled to the generator.

WARNING



You must consult a certified plumber to connect to large LP tank safely.

BEFORE STARTING THE GENERATOR



BEFORE STARTING THE GENERATOR,
REVIEW SAFETY SECTION STARTING ON
PAGE 5.

Before attempting to start the generator, verify the following:

- The engine is filled with engine oil. See *Checking Engine Oil* on page 26.
- The generator is situated in a proper location (*Location Selection* on page 16).
- The generator is on a dry surface (*Weather and Dry Surface* on page 16).
- All loads are disconnected from the generator (*No Connected Loads* on page 16).
- The generator is properly grounded the Generator (page 16).
- Propane connection is secure with no leaks or damage. See *Connecting LPG Tank* on page 19.

DANGER



Never use the generator in a location that is wet or damp. Never expose the generator to rain, snow, water spray or standing water while in use. Protect the generator from all hazardous weather conditions. Moisture or ice can cause a short circuit or other malfunction in the electrical circuit.



Never operate the generator in an enclosed area. Engine exhaust contains carbon monoxide. Only operate the generator outside and away from windows, doors and vents.

NOTICE

The engine is equipped with a low oil shutdown switch. If the oil level becomes low, the engine may shut down and not start until the oil is filled to the proper level. Poor oil quality may interfere with the operation of the low oil shutdown switch.

The owner of the generator is responsible to ensure the proper oil level is maintained during the operation of the generator. Failure to maintain the proper oil level can result in engine damage.

NOTICE

When operating on LPG it is common for frost to form on the tank and regulators. This is not an indication of a problem. The amount of frost that forms can be affected by the size of the container, the amount of fuel being used, the humidity of the air and other operating conditions. In standard use this frost may reduce flow of gas and lower performance. If frost becomes an issue try exchanging fuel tanks to allow the first tank to warm up. You can also temporarily warm the tank up by pouring warm water over the top of the propane tank.

SWITCHING FUEL SOURCES



BEFORE ADDING GAS TO THE TANK
PLEASE REVIEW FUEL SAFETY
SECTION ON PAGE 9

The below assumes that the propane fuel line is already attached to the generator securely and safely.

While the unit is running simply turn the **FUEL SELECTOR** knob to the desired fuel source. If you want to switch from gasoline to propane make sure the propane tank valve is open before you switch. When you move from propane to gasoline shut the propane valve after you have switched to gas.

NOTICE

If you do not plan on operating the unit on propane do not leave the propane tank valve open.
When starting on propane the engine may run rough for a few seconds while it purges gasoline in the carburetor.
If the engine fails when switching fuel sources simply restart the unit on the fuel source that you switched to.

OPERATION

PROGRAMMING THE GENERATOR FOR REMOTE START

NOTICE

The key fob included with the generator should come already paired with the unit. If it does not you can follow the directions below to reconnect. If your unit was shipped without a key fob please contact our customer support team.

WARNING



Always make sure the area around the generator is clear of bystanders before using the remote start to start the generator.



If you are running generator on Propane the generator cannot be stopped with remote start key fob.

The generator can be started remotely from up to a maximum of 109 yards (100 M) away using the remote start key fob with new, fully charged batteries in the key fob. As the batteries' state of charge in the key fob reduces, the distance to start the generator will also reduce.

Before the generator can be started, an initial start-up procedure must be performed so the generator and the key fob recognize each other. If the key fob is replaced, you will need to go through this procedure with the new fob.

1. With the battery connected, turn the engine control switch to the **RUN** position. The yellow battery light will illuminate.

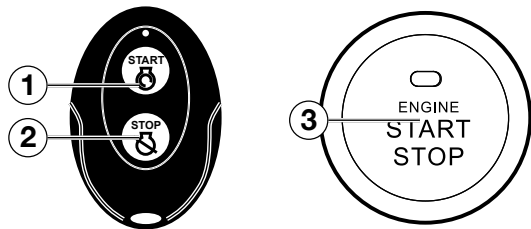

1 - Start Button | 2 - Stop Button | 3 - Push Button Start

2. Push and hold the red **REMOTE PAIRING** button on the side of the control panel until the push button start (3) on the control panel illuminates red, then let go (see 17 on page 13 for location of button).
3. Press and hold the **STOP** (2) button on the remote start key fob until the red light on the push button start (3) goes out, then let go.
4. Press and hold the **START** (1) button on the remote start key fob until the red light on the push button start (3) goes out, then let go.
5. Press and hold the **REMOTE PAIRING** button until the red light on the push button start (3) goes out. The generator is now programmed to start remotely.

POWER OUTPUT AND DEMAND

The generator should not be run completely unloaded for extended periods otherwise the engine may be damaged. It is recommended that the generator should always be operated with at least one-third of its rated 120-Volt AC power output. 120-Volt AC devices have two different electric power demands that must be taken into consideration, namely the running power and the starting/peak power. Both are measured in Watts (typically abbreviated as "W").

The steady state continuous load is the running power demand and this is often marked on the device near its model number or serial number. Sometimes the device might only be marked with its voltage (i.e. 120 V) and current draw (e.g. 6 Amp or 6 A), in which case the running power demand in Watts can be obtained by multiplying the voltage times the current, e.g. $120\text{ V} \times 20\text{ A} = 2,400\text{ W}$.

Simple resistive 120-Volt AC devices such as incandescent bulbs, toasters, heaters, etc. have no extra power demand when starting, and so their starting power demands are the same as their running power demands.

More complex 120-Volt AC devices containing inductive or capacitive elements such as electric motors have a momentary extra power demand when starting, which can be up to seven times the running power demand or more. Manufacturers of such devices rarely publish this starting power demand and so it's often necessary to estimate it. A rule of thumb for devices fitted with an electric motor is to apply a starting power multiplier of 1.2 for small hand-held or portable devices and a value of 3.5 for larger stationary devices. For example, a 900 W angle grinder can be assumed to have a starting power demand of at least $1.2 \times 900\text{ W}$, which equals 1,080 W. Similarly, a 1,650 W air compressor can be assumed to have a starting power demand of at least $3.5 \times 1,650\text{ W}$, which equals 5,775 W.

To prevent overloading of the generator's 120-Volt AC system:

1. Add up the running power demand of all the 120-Volt AC devices that will be connected to the generator at one time. This total must not be greater than the generator's specified running power output.
2. Add up the running power demand again, but for the largest motor-driven device use the value of its starting power demand instead of its running power demand. This total must not be greater than the generator's specified starting power output.
3. The total running power demand of all the devices that will be connected to any one of the generator's outlets must not exceed the generator's specified running power output or 3,700 W, whichever is the lesser.

OPERATION

ELECTRIC START

Be sure to check oil levels before starting. If it is the first time starting make sure to add oil (see *Adding Engine Oil* page 26).

1. Make sure nothing is plugged into power outlets
2. Verify the battery is properly installed and both battery cables are attached (see *Connecting the Battery* on page 12).
3. Make sure the circuit breakers are properly set (see Figure 8).

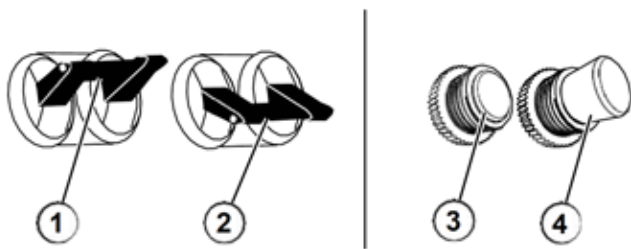

Figure 8 - Breakers

- ① 240/120V Main Circuit Breaker Operating Position
- ② 240/120V Main Circuit Breaker Tripped Position
- ③ 120V Circuit Breaker Operating Position
- ④ 120V Circuit Breaker Tripped Position

4. Select fuel source for start up:

FOR GASOLINE:

- a. Move the fuel shut off valve to the **ON** position (see Figure 9).
- b. Turn fuel selector knob to **GASOLINE** (see Figure 9).

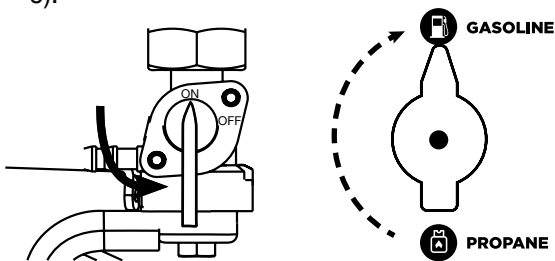

Figure 9 - Fuel Shut Off - ON
Fuel Selector - GASOLINE

FOR LPG/PROPANE:

- a. Make sure the LPG hose is safely secured from the generator to the tank (see *Connecting the LPG Tank* on page 19).
- b. Turn the fuel selector knob to **PROPANE** (see Figure 10).
- c. Fully open the valve on the propane tank.

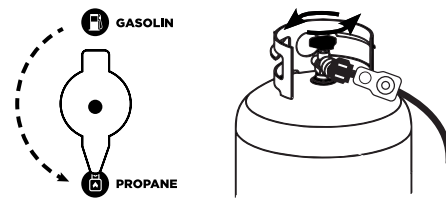

Figure 10 - Fuel Selector - PROPANE
Propane Tank Valve - OPEN

5. Push the engine control switch into the **RUN** position (see Figure 11).

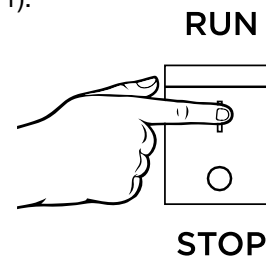
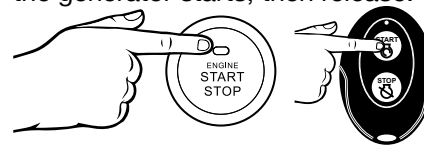

Figure 11 - Engine Control Switch - RUN

6. Push and hold the push button start until the generator starts, then release. If using remote start then hold down **START** on the remote key fob until the generator starts, then release.



The engine will automatically set the choke and begin the start sequence.

- If the engine has started successfully the light indicator on the engine start button will turn green.
- If the engine fails to start, the generator controls will attempt to start the engine two more times for a total of three attempts.
- If the third attempt fails, the light on the engine start button will turn red.
- If the engine has failed to start after three attempts the push button start can be pushed again to begin the automatic start sequence.
- The engine control switch can be switched at any time during the automatic start sequence to abort the engine start attempt.

NOTE: If the cranking speed drops after each unsuccessful attempt, then the battery may not be adequately charged. You can alternatively start the generator using the recoil start as instructed in *Manually Starting a Generator* on page 23.

7. Plug in electric devices.

OPERATION

MANUALLY STARTING THE GENERATOR

Be sure to check oil levels before starting. If it is the first time starting make sure to add oil (see *Adding Engine Oil* page 26).

1. Make sure nothing is plugged into power outlets
2. Make sure the circuit breakers are properly set (see Figure 8).
4. Select fuel source (see Step 4 on page 22)
5. Push the engine control switch into the RUN position (see Figure 11).
6. Manually set the choke:
 - a. Cold Start: Close the choke by moving it right towards the front handle of the generator.

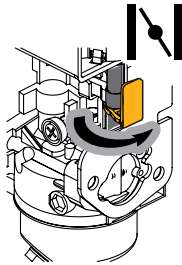

Choke position for cold start.

- b. Warm Start: Open the choke by moving it left towards the wheels of the generator.

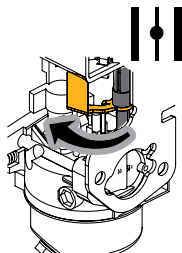

Choke position for warm start.

7. Firmly grasp and pull the recoil handle slowly until you feel increased resistance. At this point, apply a rapid pull while pulling up and slightly away from the generator (see Figure 12).

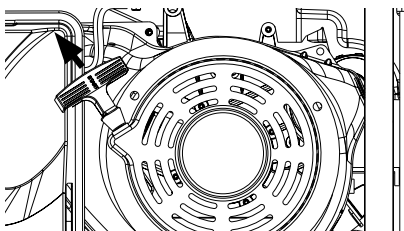

Figure 12 - Pull recoil

8. Plug in electric devices.

STOPPING THE GENERATOR

Normal Operation

During normal operation, use the following steps to stop your generator:

1. Remove any connected loads from the control panel receptacles.
2. Allow the generator to run at “no load” to reduce and stabilize engine and alternator temperatures.
3. Choose from options below to stop the generator (see Figure 13):
 - Position the engine control switch to **STOP**
 - Hold push button start until the generator stops
 - Hold the **STOP** button on the remote start key fob (Note: The generator will run for an additional 15 seconds as it goes through a cool down cycle before shutting off.)

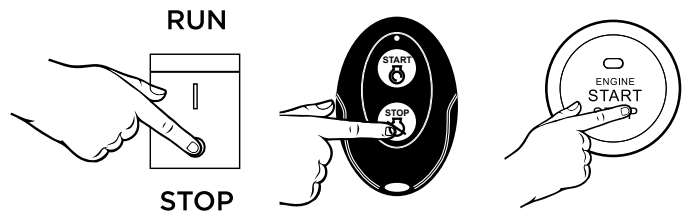

Figure 13 - Stopping the generator

NOTE If you plan to store the generator after use, stop the generator by turning the fuel shutoff valve to the **OFF** position and allow the fuel to be consumed from the carburetor.

4. If running off of propane then close the propane valve. If running on gas turn the fuel shutoff valve to the **OFF** position.

During an Emergency

If there is an emergency and the generator must be stopped quickly, position the engine control switch to the **STOP** position immediately.

MAINTENANCE



BEFORE PERFORMING MAINTENANCE ON THE GENERATOR, REVIEW THE SAFETY SECTION STARTING ON PAGE 5, AS WELL AS THE FOLLOWING SAFETY MESSAGES.

⚠ WARNING



Avoid accidentally starting the generator during maintenance by removing the spark plug boot from the spark plug. For electric start generators, also disconnect the battery cables from the battery (disconnect the black negative (-) cable first) and place the cables away from the battery posts to avoid arcing.



Allow hot components to cool to the touch prior to performing any maintenance procedure.



Internal pressure can build in the engine crankcase while the engine is running. Removing the oil fill plug/ dipstick while the engine is hot can cause extremely hot oil to spray out of the crankcase and can severely burn skin. Allow engine oil to cool for several minutes before removing the oil fill plug/dipstick.



Always perform maintenance in a well-ventilated area. Gasoline fuel and fuel vapors are extremely flammable and can ignite under certain conditions.

MAINTENANCE SCHEDULE

⚠ WARNING



Failure to perform periodic maintenance or not following maintenance procedures can cause the generator to malfunction and could result in death or serious injury.

NOTICE

Periodic maintenance intervals vary depending on generator operating conditions. Operating the generator under severe conditions, such as sustained high-load, high-temperature, or unusually wet or dusty environments, will require more frequent periodic maintenance. The intervals listed in the maintenance schedule should be treated only as a general guideline.

⚠ CAUTION



Avoid skin contact with engine oil or gasoline. Prolonged skin contact with engine oil or gasoline can be harmful. Frequent and prolonged contact with engine oil may cause skin cancer. Take protective measures and wear protective clothing and equipment. Wash all exposed skin with soap and water.

Following the maintenance schedule is important to keep the generator in good operating condition. The following is a summary of maintenance items by periodic maintenance intervals.

TABLE 1: MAINTENANCE SCHEDULE - OWNER PERFORMED

Maintenance Item	Before Every Use	After First 20 Hours or First Month of Use	After 50 Hours of Use or Every 6 Months	After 100 Hour of Use or Every 6 Months	After 300 Hours of Use or Every Year
Engine Oil	Check Level	Change	Change	-	-
Cooling Features	Check/Clean	-	-	-	-
Air Filter	Check	-	Clean*	-	Replace
Spark Plug	-	-	-	Check/Clean	Replace
Spark Arrestor	-	-	-	Check/Clean	-

*Service more frequently if operating in dry and dusty conditions

MAINTENANCE

TABLE 2: MAINTENANCE SCHEDULE - AUTHORIZED WESTINGHOUSE SERVICE DEALER PERFORMED

Maintenance Item	Before Every Use	After First 20 Hours or First Month of Use	After 50 Hours of Use or Every 6 Months	After 100 Hour of Use or Every 6 Months	After 300 Hours of Use or Every Year
Valve Clearance	-	-	-	-	Check/Adjust
Fuel Filter	-	-	-	Check/Clean	-
Idle Speed	-	-	-	-	Check/Adjust

CLEANING THE SPARK ARRESTOR

⚠ WARNING



Hot Surfaces. When operating machine, do not touch hot surfaces. Keep machine away from combustibles during use. Hot surfaces could result in severe burns or fire.

Check and clean the spark arrestor after every 100 hours of use or 6 months.

1. Generator must be cold to perform this maintenance.
2. Move the inverter to a flat, level surface.
3. Remove the 6 screws holding the muffler cover in place (see Figure 14).

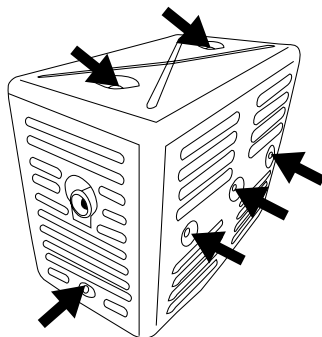

Figure 14: Remove screws holding muffler cover

4. Once the cover is removed, locate the screw on the tip of the muffler and remove. Pull the spark arrestor out of the muffler. (see Figure 15).

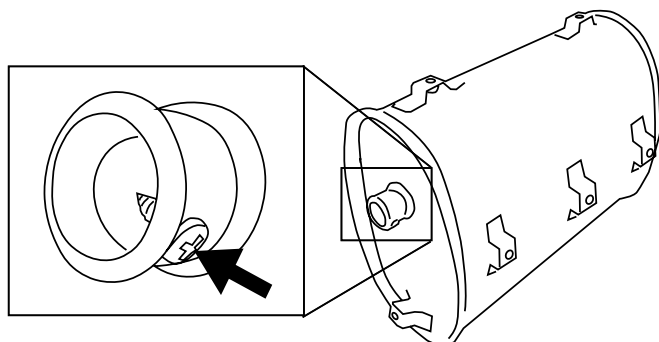

Figure 15: Remove spark arrestor

5. If the spark arrestor screen shows signs of wear (rips, tears or large openings in the screen), replace the spark arrestor screen. **NOTE:** Only use Westinghouse spark arrestors as replacements.
6. If screen is not torn then clean using a wire brush, commercial solvent, or compressed air. Remove any dirt and debris that may have collected on the spark arrestor screen (see Figure 16).

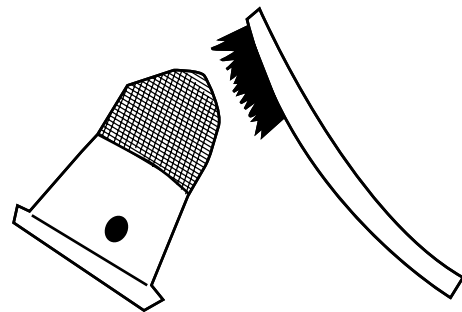
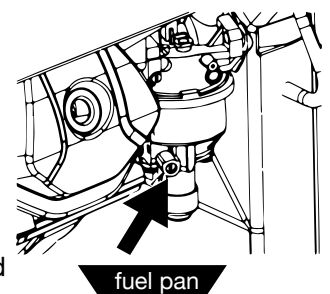

Figure 16: Clean spark arrestor

7. Install the spark arrestor back into the muffler. Make sure to fully push it in so that it is tight on the tip of the muffler.
8. Replace the muffler cover and tighten all 6 screws.

DRAINING CARBURETOR FLOAT BOWL

1. Make sure the generator is off and you are away from any open flames.
2. Place pan (or suitable container) under the carburetor assembly.
3. Loosen screw at bottom of the bowl and allow gas to drain out.
4. After all the gas has drained out, tighten the screw.



MAINTENANCE

ENGINE OIL MAINTENANCE

Engine Oil Specification

1. Only use the engine oil specified in Figure 17.
2. Only use 4-stroke/cycle engine oil. **NEVER USE 2-STROKE/CYCLE OIL.** Synthetic oil is an acceptable substitute for conventional oil.

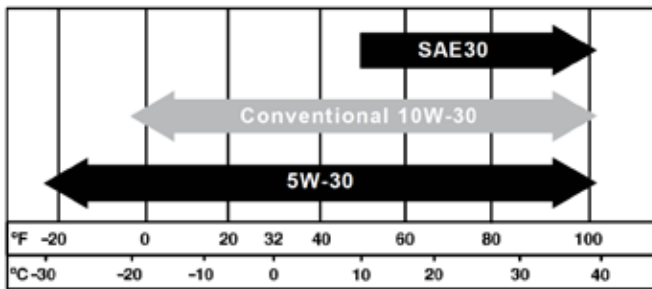

Figure 17 - Recommended Oil

CHECKING ENGINE OIL

NOTICE

Always maintain proper engine oil level. Failure to maintain proper engine oil level could result in severe damage to the engine and/or shorten the life of the engine. Always use the specified engine oil. Failure to use the specified engine oil can cause accelerated wear and/or shorten the life of the engine.

Engine oil level should be checked before every use.

1. Always operate or maintain the generator on a flat surface.
2. Stop engine if running.
3. Let engine sit and cool for several minutes (allow crankcase pressure to equalize).
4. With a damp rag, clean around the oil fill plug/dipstick.
5. Remove oil fill plug/dipstick (see Figure 18 below).

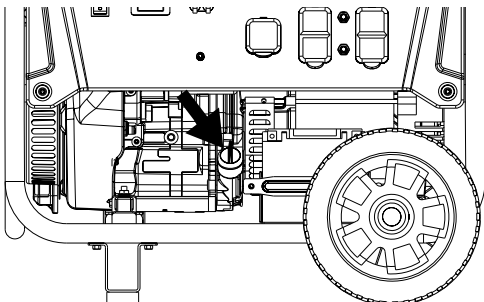

Figure 18 - Oil Fill Plug/Dipstick

6. Check oil level: When checking the engine oil, remove the oil fill plug/dipstick and wipe it clean. Thread the oil fill plug/dipstick all the way back in and then remove and check the oil level on the oil fill plug/dipstick.
 - **Acceptable Oil Level** – Oil is visible on the crosshatches between the H and L lines on the oil fill plug/dipstick (see Figure 19).
 - **Low Oil** – Oil is below the L line on the oil fill plug/dipstick.

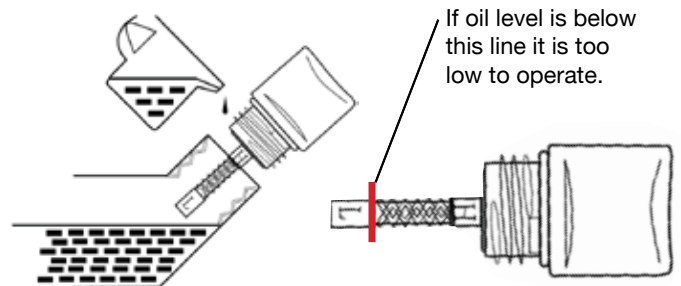

Figure 19 - Checking Oil Level

ADDING ENGINE OIL

1. Always operate or maintain the generator on a flat surface.
2. Stop engine if running.
3. Let engine sit and cool for several minutes (allow crankcase pressure to equalize).
4. Thoroughly clean around the oil fill plug/dipstick.
5. Remove oil fill plug/dipstick and wipe clean.
6. Select the proper engine oil as specified in Figure 17.
7. Using the supplied funnel, slowly add engine oil to the engine. Stop frequently to check the level to avoid overfilling.
8. Continue to add oil until the oil is at the correct level. See Figure 19.
9. Replace the oil fill plug/dipstick.

MAINTENANCE

CHANGING ENGINE OIL

1. Always operate or maintain the generator on a flat surface.
2. Stop the engine.
3. Let engine sit and cool for several minutes (allow crankcase pressure to equalize).
4. Place oil pan (or suitable container) under the oil drain plug (see Figure 20).
5. With a damp rag, thoroughly clean around the oil drain plug.
6. Remove the oil drain plug (see Figure 20). Once removed, place the oil drain plug on a clean surface.

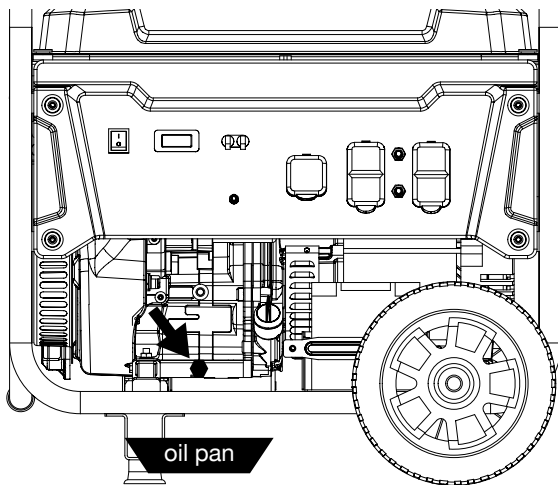

Figure 20 - Oil Drain Plug

7. Allow oil to completely drain.
8. Replace oil drain plug.
9. Fill crankcase with oil following the steps outlined in *Adding Engine Oil* on page 26.

NOTICE

Never dispose of used engine oil by dumping the oil into a sewer, on the ground, or into ground water or waterways. Always be environmentally responsible. Follow the guidelines of the EPA or other governmental agencies for proper disposal of hazardous materials. Consult local authorities or reclamation facility.

AIR FILTER MAINTENANCE

⚠ WARNING



Never use gasoline or other flammable solvents to clean the air filter. Use only household detergent soap to clean the air filter.

Cleaning the Air Filter

The air filter must be cleaned after every 50 hours of use or 3 months (frequency should be increased if generator is operated in a dusty environment).

1. Turn off the generator and let it cool for several minutes if running.
2. Move the generator to a flat, level surface.
3. Unclip the clips on the top and bottom of the air filter cover (Figure 21).

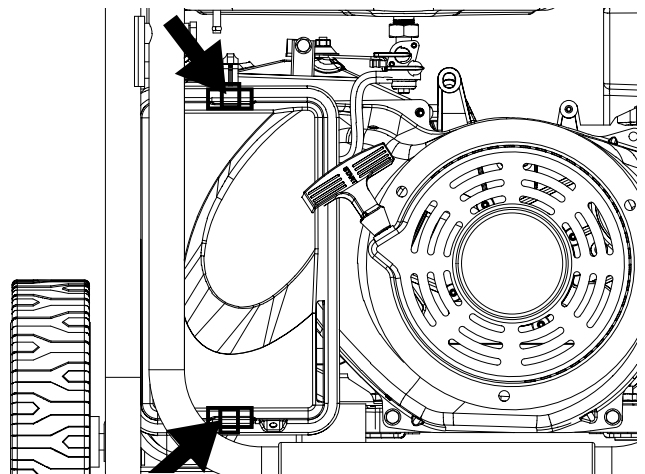

Figure 21 - Unclip air filter

4. Remove the black coarse air filters.
5. Wash the foam air filter elements by submerging the elements in a solution of household detergent soap and warm water. Slowly squeeze the foam to thoroughly clean.

NOTICE

NEVER twist or tear the foam air filter element during cleaning or drying. Only apply slow but firm squeezing action.

6. Rinse in clean water by submerging the air filter elements in fresh water and applying a slow squeezing action

MAINTENANCE

Cleaning the Air Filter - Continued from Page 27

NOTICE

Never dispose of soap cleaning solution used to clean the air filter by dumping the solution into a sewer, on the ground, or into ground water or waterways. Always be environmentally responsible. Follow the guidelines of the EPA or other governmental agencies for proper disposal of hazardous materials. Consult local authorities or reclamation facility.

7. Dispose of used soap cleaning solution properly.
8. Dry the air filter elements by again applying a slow firm squeezing action.
9. Once the air filters are dry, coat the air filters with clean engine oil (see Figure 22).



Figure 22

10. Squeeze the filters to remove any excess oil.
11. Install the filters back into the unit. Make sure the gray (fine) air filter goes in first followed by the black (coarse) air filter on the outside.
12. Install the air filter cover and secure the air filter assembly.

SPARK PLUG MAINTENANCE

The spark plug must be checked and cleaned after every 100 hours of use or 6 months and must be replaced after 300 hours of use or every year.

1. Stop the generator and let it cool for several minutes if running.
2. Move the generator to a flat, level surface.
3. Remove the spark plug boot by firmly pulling the plastic spark plug boot handle directly away from the engine (see Figure 23).

NOTICE

Never apply any side load or move the spark plug laterally when removing the spark plug. Applying a side load or moving the spark plug laterally may crack and damage the spark plug boot.

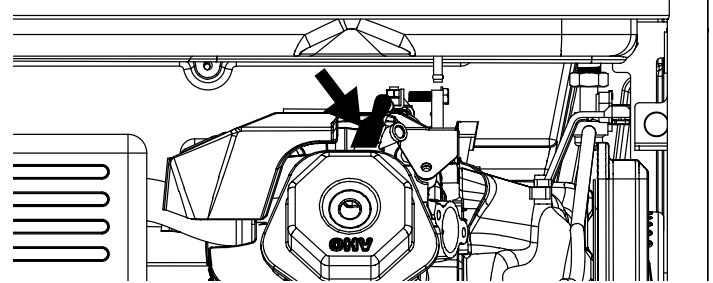
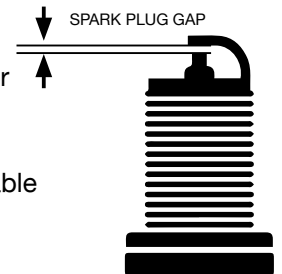

Figure 23 - Remove Spark Plug Boot

4. Clean area around the spark plug.
5. Using the 13/16" spark plug socket wrench provided, remove the spark plug from the cylinder head.
6. Place a clean rag over the opening created by the removal of the spark plug to make sure no dirt can get into the combustion chamber.

Inspect the spark plug for:

- Cracked or chipped insulator
- Excessive wear
- Spark plug gap (the acceptable limit of 0.027–0.032 in. [0.70 – 0.80 mm]).



NOTICE

Use only recommended spark plugs when servicing. The manufacturer is not responsible for engine damage when using spark plugs not recommended by the manufacturer.

7. Install the spark plug by carefully following the steps outlined below:
 - a. Carefully insert the spark plug back into the cylinder head. Hand-thread the spark plug until it bottoms out.
 - b. Using the 13/16" spark plug socket wrench provided, turn the spark plug to ensure it is fully seated.
 - c. Replace the spark plug boot, making sure the boot fully engages the spark plug's tip.

Recommended Spark Plug Replacement:

NGK: (1034) BP7ES (Replacement)

Torch: F7TC (OE Spark Plug)

Westinghouse Part Number: 180526

MAINTENANCE

CHECKING AND ADJUSTING VALVE LASH

⚠ CAUTION



Checking and adjusting valve lash must be done when the engine is cold.

1. Remove the rocker arm cover and carefully remove the gasket. If the gasket is torn or damaged, it must be replaced.
2. Remove the spark plug so the engine can be rotated more easily.
3. Rotate the engine to top dead center (TDC) of the compression stroke. Looking through the spark plug hole, the piston should be at the top.
4. Both the rocker arms should be loose at TDC on the compression stroke. If they are not, rotate the engine 360°.
5. Insert a feeler gauge between the rocker arm and the push rod and check for clearance (see Figure 24). See Table 3 for valve lash specifications.

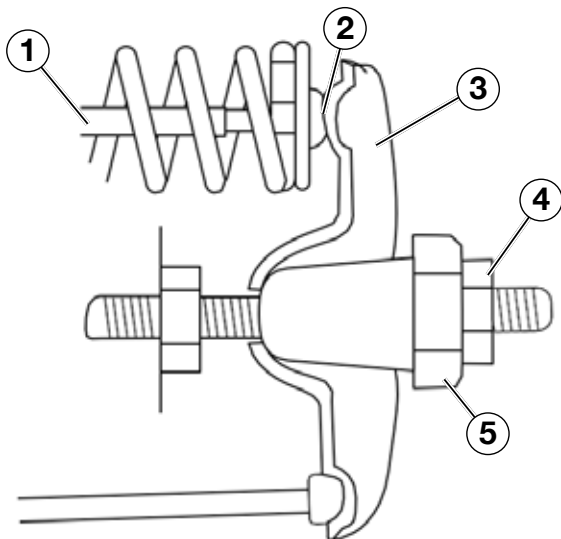

Figure 24

(1) Push Rod, (2) Feeler Gauge Area
(3) Rocker Arm, (4) Jam Nut, (5) Adjusting Nut

(Table 3) Standard Valve Lash

	Intake Valve	Exhaust Valve
Valve Lash	0.0035 ± 0.0043 in (0.09 ± 0.11 mm)	0.0043 ± 0.0051 in (0.11 ± 0.13 mm)
Bolt Torque	8-12N.m	8-12N.m

6. If an adjustment is required, hold the adjusting nut and loosen the jam nut.
7. Turn the adjusting nut to obtain the correct valve lash. When the valve lash is correct, hold the adjusting nut and tighten the jam nut to 106 in-lb (12 N•m).
8. Recheck the valve lash after tightening the jam nut.
9. Perform this procedure for both the intake and exhaust valves.
10. Install the rocker arm cover, gasket and spark plug.

TESTING GFCI OUTLETS

1. Start the generator and allow it to warm up.
2. Press the test button on the GFCI outlet.

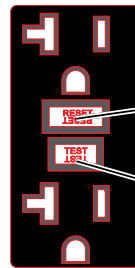

Reset Button

Test Button

3. The reset button should pop out and there will be no power from the outlets. If the reset button does not pop out, the GFCI outlet is not working correctly and must be repaired before the generator can be operated.
4. Press the reset button to restore power to the outlet.

BATTERY SERVICE

⚠ WARNING



Do not charge for over 8 hours. Leaving the charger plugged in indefinitely could overcharge the battery and lead to battery failure.

To ensure the battery remains charged, the generator should be started every 2 to 3 months and run for a minimum of 15 minutes or a charger should be plugged into the generator and the generator should be charged overnight. Make sure the engine control switch is in the **STOP** position when charging. Plug the cord from the charger into the charging port on the generator control panel. Plug the charger into a 110/120-volt AC outlet.

MAINTENANCE

BATTERY REPLACEMENT

1. Remove the spark plug wire from spark plug.
2. Loosen and remove the bolt on the battery hold-down plate and swing the plate out.
3. Tip the battery forward slightly to access battery cables.
4. Disconnect the black negative (-) battery cable from the battery first.
5. Disconnect the red positive (+) battery cable second and remove the battery.

NOTICE

Dispose of the used battery properly according to the guidelines established by your local or state government.

6. Install the new battery into the generator frame.
7. Connect the red positive (+) battery cable to the battery first.
8. Connect the black negative (-) battery cable to the battery second.
9. Install the battery hold-down plate using the nuts removed in step 2.
10. Install the spark plug wire onto spark plug.

See below for the battery specification when replacing the battery.

Westinghouse Part No.	100557
After Market Battery Model	YT9A
Volts	12
Amp Hr	9
Dimensions	5 5/16in by 3in by 5 3/8in

CLEANING THE GENERATOR

It is important to inspect and clean the generator before every use.

Clean All Engine Air Inlet and Outlet Ports – Make sure all engine air inlet and outlet ports are clean of any dirt and debris to ensure the engine does not run hot.

Clean All Engine Cooling Fins – Use a damp rag and a brush to loosen and remove all dirt on or around the engine's cooling fins.

Clean All Alternator Cooling Air Inlets and Exhaust Ports – Make sure the cooling air inlets and exhaust ports of the alternator are free of any debris and obstructions. Use a vacuum cleaner to remove dirt and debris stuck in the cooling air inlets and exhaust ports.

30 | Westinghouse Portable Power

General Cleaning of the Generator – Use a damp rag to clean all remaining surfaces.

STORING GENERATOR

WARNING



Never store a generator with fuel in the tank indoors or in a poorly ventilated area where the fumes can come in contact with an ignition source such as a: 1) pilot light of a stove, water heater, clothes dryer or any other gas appliance; or 2) spark from an electric appliance.

NOTICE

Gasoline stored for as little as 60 days can go bad, causing gum, varnish and corrosive buildup in fuel lines, fuel passages and the engine. This corrosive buildup restricts the flow of fuel, preventing an engine from starting after a prolonged storage period.

Proper care should be taken to prepare the generator for any storage.

1. Make sure the Engine Switch is switched to **STOP** so the generator does not draw power from battery.
2. Clean the generator as outlined in *Cleaning the Generator*.
3. Drain all gasoline from the fuel tank as best as possible.
4. With the fuel shut off valve open, start the engine and allow the generator to run until all the remaining gasoline in the fuel lines and carburetor is consumed and the engine shuts off. If you used propane the last time you ran the generator: start the unit up with propane then shut off the propane tank valve allowing the engine to use up all the remaining propane in the carburetor before it shuts off.
5. Close the fuel shut off valve.
6. Drain the remaining gas in the carburetor float bowl outlined in *Draining Carburetor Float Bowl* on page 25.
7. Change the oil (see Changing Engine Oil on page 27).
8. Remove the spark plug (see Spark Plug Maintenance on page 28) and place about 1 tablespoon of oil in the spark plug opening. While placing a clean rag over the spark plug opening, slowly pull there coil handle to allow the engine to turn over several times. This will distribute the oil and protect the cylinder wall from corroding during storage.
9. Replace the spark plug (see Spark Plug Maintenance on page 28).
10. Move the generator to a clean, dry place for storage.

TROUBLESHOOTING

⚠ WARNING



Before attempting to service or troubleshoot the generator, the owner or service technician must first read the owner's manual and understand and follow all safety instructions. Failure to follow all instructions may result in conditions that can lead to voiding of the EPA certification or product warranty, serious personal injury, property damage or even death.

PROBLEM	POTENTIAL CAUSE	SOLUTION
Engine is running, but no electrical output	1. Circuit breakers are tripped.	1. Reset the circuit breakers and check for overload condition.
	2. The power cord's plug connector is not fully engaged in the generator's outlet.	2. Verify plug connector is firmly engaged in the generator's outlet. If using the 240V outlet, make sure plug connector is rotated 1/4 turn in the clockwise direction.
	3. Faulty or defective power cord	3. Replace power cord.
	4. Faulty or defective electrical appliance	4. Try connecting a known good appliance to verify the generator is producing electrical power.
	5. GFCI outlet is tripped	5. Press the reset button on the GFCI outlet.
	6. If trying 1-5 above does not solve the problem, the cause might be the generator has a fault.	6. Take the generator to your nearest authorized service dealer.
Engine will not start or remain running while trying to start.	1. Fuel shutoff valve is in the OFF position.	1. Move the fuel shut off valve to the ON position.
	2. Generator is out of gasoline.	2. Add gasoline to the generator.
	3. Fuel flow is obstructed.	3. Inspect and clean fuel delivery passages.
	4. Starting battery may have insufficient charge	4. On electric start models only. Check battery output and charge battery as necessary.
	5. Dirty air filter	5. Check and clean the air filter.
	6. Low oil level shut down switch is preventing the unit from starting.	6. Check oil level and add oil if necessary.
	7. Spark plug boot is not fully engaged with the spark plug tip.	7. Firmly push down on the spark plug boot to ensure the boot is fully engaged
	8. Spark plug is faulty.	8. Remove and check the spark plug. Replace if faulty.
	9. Dirty/plugged spark arrestor	9. Check and clean the spark arrestor.
	10. Stale fuel	10. Drain fuel and replace with fresh fuel.
	11. If trying 1-10 above does not solve the problem, the cause might be the generator has a fault.	11. Take the generator to your nearest authorized service dealer.
Generator suddenly stops running.	1. Generator is out of fuel.	1. Check fuel level. Add fuel if necessary.
	2. The low oil shut down switch has stopped the engine.	2. Check oil level and add oil if necessary.
	3. Too much load	3. Restart the generator and reduce the load.
	4. If trying 1-3 above does not solve the problem, the cause might be a fault in the generator.	4. Take the generator to your nearest authorized service dealer.

TROUBLESHOOTING

PROBLEM	POTENTIAL CAUSE	SOLUTION
Engine runs erratic; does not hold a steady RPM.	1. Dirty air filter	1. Clean the air filter.
	2. Applied loads maybe cycling on and off	2. As applied loads cycle, changes in engine speed may occur; this is a normal condition.
	3. If trying 1-3 above does not solve the problem, the cause might be a fault in the generator	3. Take the generator to your nearest authorized service dealer.
Push button start is not working and the cranking speed drops after each attempt.	1. Battery is not adequately charged	1. Turn the engine switch to "STOP" and hook up the battery charger for 1 hour. 2. Try manually starting the generator to let the battery charge while it is operating.
Frost on the propane tank or regulator	1. This can be a normal occurrence caused when liquid propane changes phase to a gas. As this process occurs the fuel tank or regulator will cool and allow humid air surrounding the propane tank or regulator to condense into frost.	1. As this can be normal, providing all the propane fuel handling equipment is functioning normally, no remedy is needed.
	2. The propane tank is not equipped with a OPD (rollover protection device) and has been stored in a horizontal position allowing liquid propane to enter the downstream fuel handling equipment.	2. If you suspect your propane fuel tank is not equipped with a OPD device, discontinue operation immediately and replace the propane fuel tank with a propane tank equipped with a roll over protection device.
	3. Propane fuel tank over filled.	3. If you suspect your propane fuel tank has been overfilled, discontinue operation immediately and return the propane fuel tank to the place of purchase or refilling.
Propane fuel smell	1. Fuel regulator or fuel hose and fittings not securely sealed.	1. Using a soap solution check each connection and tighten as needed.
	2. Propane fuel regulator vent active.	2. The propane fuel regulator is equipped with a small vent that will allow a small amount of propane fuel vapor to escape from the regulator when the propane tank valve is opened. This can be normal providing the venting of the propane is brief. If you suspect that this is abnormal, immediately discontinue use and have the propane regulator inspected by a qualified technician.
	3. Residual fuel from the carburetor dispersing after operation.	3. Normal, no remedy is needed.
Poor performance or engine stalling	1. Propane fuel line kinked or crushed.	1. Inspect propane fuel line and remove kinks or other obstructions.
	2. Fuel selector valve not properly positioned.	2. Rotate the fuel valve fully until the pointer is directly in line with the desired fuel.
	3. Gasoline not purged from the carburetor before switching to propane.	3. Turn the propane fuel tank valve to closed. Move the fuel selector valve to propane. Turn the gasoline fuel valve to off. Start the engine and allow the engine to run until the fuel has been consumed in the carburetor. Begin propane start up procedure.

WGen7500DF SCHEMATIC

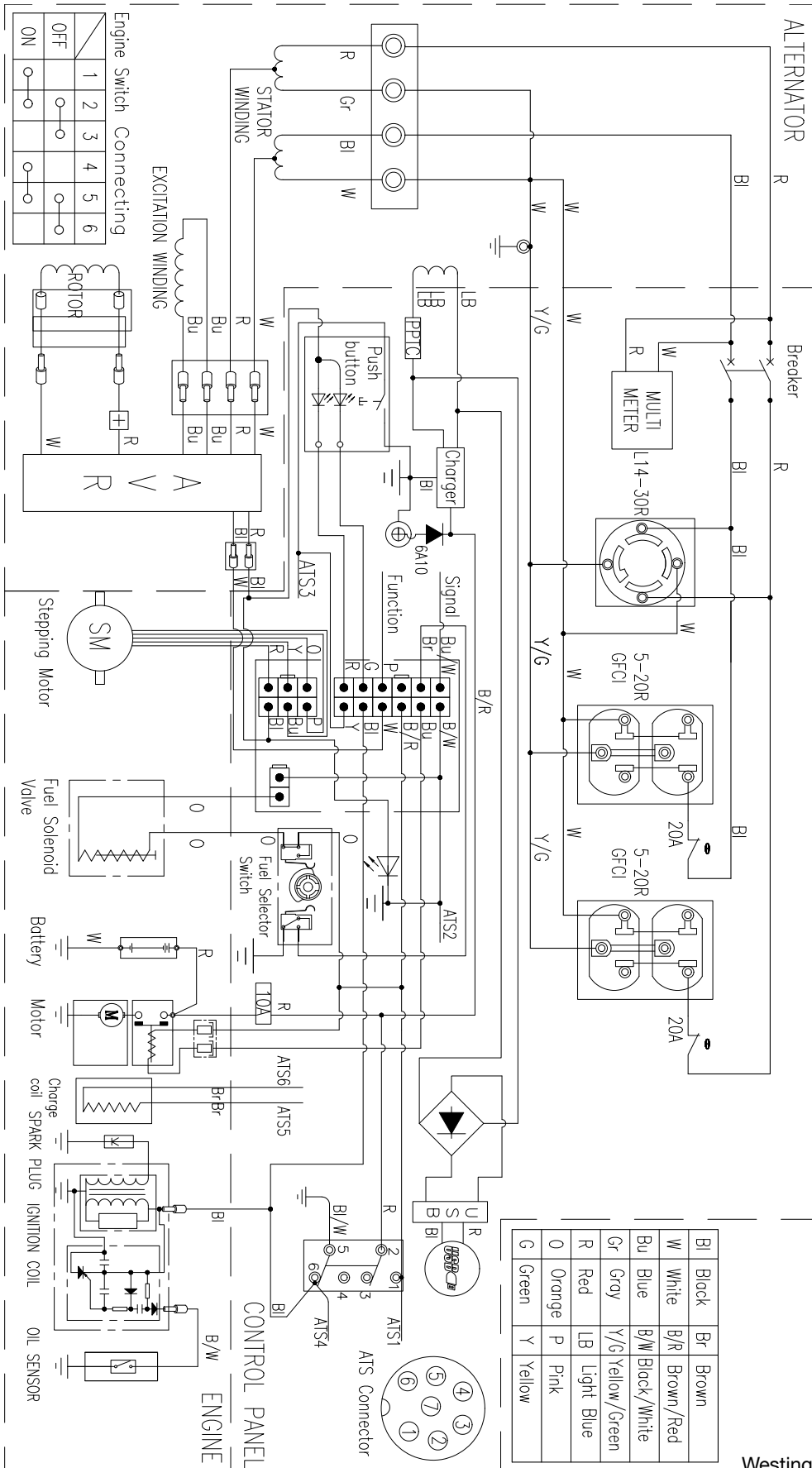

WGen7500DF EXPLODED VIEW

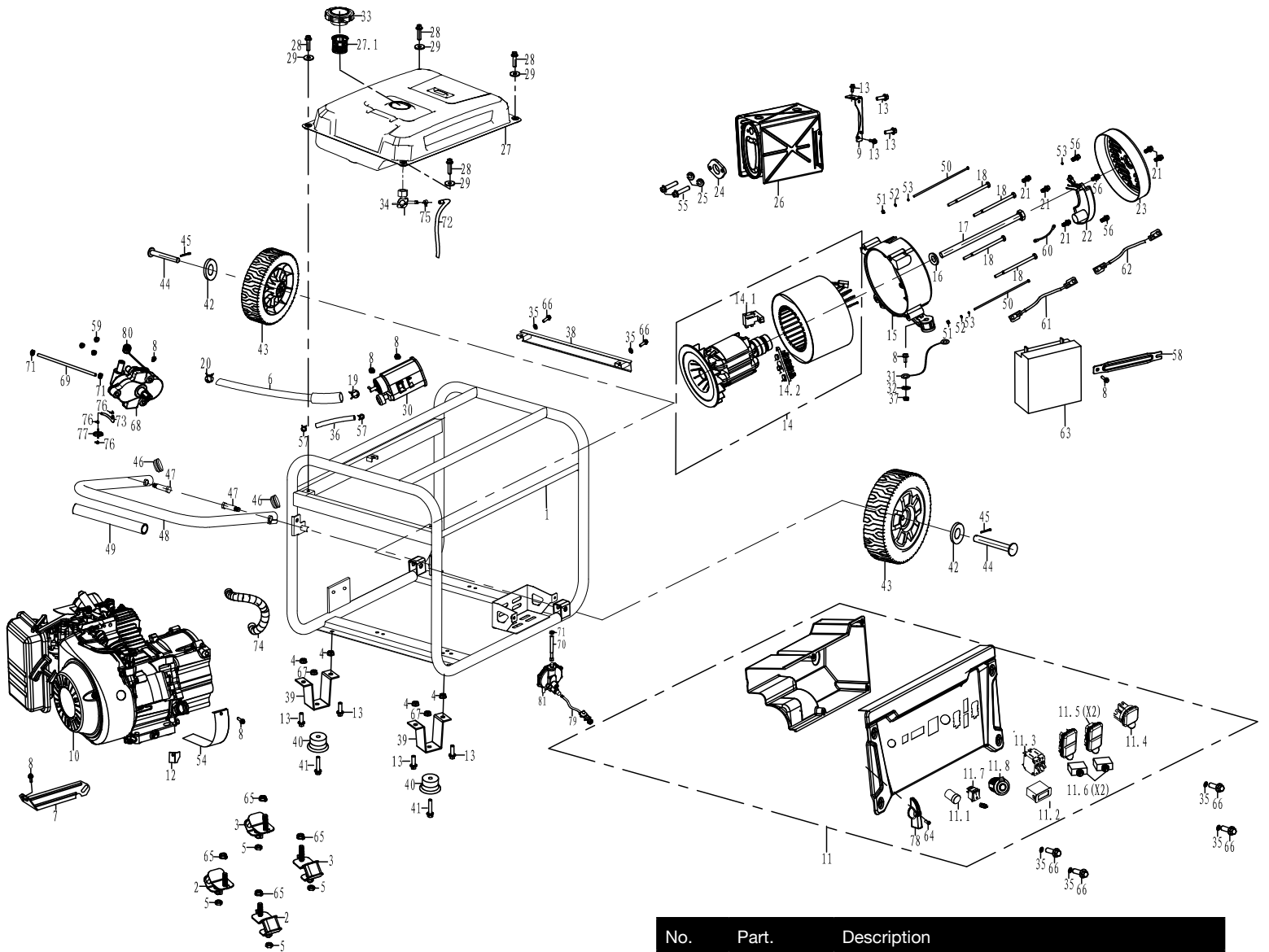

No.	Part.	Description
1	100500	FRAME
2	100552	ISOLATOR B
3	100553	ISOLATOR A
4	100520	NUT M8
5	180524	NUT M8
6	150507	CARB CANISTER CONNECTING PIPE LONG
7	180563	BRACKET, AIR CLEANER
8	120505	BOLT M6X12
9	110504	MUFFLER BRACKET
10	180590	ENGINE ASSY
11	130527	PANEL COMP
11.1	130528	ONE-PUSH START SWITCH

No.	Part.	Description
11.2	130529	THREE IN ONE DIGITAL DISPLAY.
11.3	130530	CIRCUIT BREAKER 30/2P/31A
11.4	130531	NEMA L14-30R 120V/240V 30A TWISTLOCK
11.5	130532	GFCI RECEPTACLE
11.6	130553	THERMAL PROTECTOR 20A
11.7	130534	RUN STOP SWITCH
11.8	130540	DUAL USB DC SOCKET
12	180562	DUSTPROOF SHEET
13	100516	BOLT M8X16
14	120540	ALTERNATOR ASSY
14.1	120502	CARBON BRUSH COMP
14.2	120503	GROUNDING POST COMP
15	120504	MOTOR STAND
16	100540	GASKET, ROTOR BOLT M10.5XM30X4
17	120514	BOLT M10X1.25X275
18	120513	BOLT M6X190

WGen7500DF EXPLODED PART NO.

No.	Part.	Description
19	150508	CLIP, FUEL LINE $\Phi 9 \times 0.8$
20	140539	CLIP, FUEL LINE $\Phi 10$
21	120537	BOLT M5X12
22	120517A	AUTOMATIC VOLTAGE REGULATOR
23	120519	END COVER, GENERATOR
24	110501	GASKET, EXHAUST PIPE
25	110502	SPRING WASHER $\Phi 8$
26	110500	MUFFLER COMP
27	150546	FUEL TANK ASSEMBLY
27.1	150506	FUEL FILTER
28	120541	BOLT M6X25
29	150501	WASHER FUEL TANK
30	150512	CARBON TANK COMP
31	120542	GROUNDING WIRE
32	120508	TOOTH TYPE GASKET $\Phi 8$
33	150505	FUEL TANK CAP COMP
34	150548	FUEL COCK
35	100547	BRACKET WASHER
36	150510	CARB CANISTER CONNECTING PIPE SHORT
37	120506	NUT M6
38	100581	FUEL FRAME BRACKET
39	100512	FOOT BRACKET
40	100515	VIBRATION ISOLATION PAD, SQUARE
41	100582	BOLT M6X28
42	100510	FLAT WASHER $\Phi 13 \times \Phi 37 \times 4$
43	100506	WHEEL
44	100504	AXLE
45	100508	COTTER PIN
46	100527	PLUG, HANDLE
47	100525	BOLT, HANDLE M10X $\Phi 12.5 \times 53.5$
48	100521	HANDLE ASSEMBLY
49	100523	RUBBER, HANDLE
50	120509	BOLT M5X224
51	120510	NUT M5
52	120511	FLAT WASHER $\Phi 5$
53	120512	SPRING WASHER $\Phi 5$
54	180561	GUARD COVER, CRANKCASE
55	110503	BOLT M8X30
56	120518	BOLT M5X16
57	150549	CLIP, FUEL LINE $\Phi 8$
58	100558	BATTERY HOLDER
59	100583	NUT M5
60	120543	GROUNDING WIRE
61	100555	NEGATIVE LEAD

No.	Part.	Description
62	100584	POSITIVE LEAD
63	100557	BATTERY
64	130535	HEXAGON PATTERN PAN HEAD SCREWS
65	100551	NUT M10
66	130536	BOLT M6X16
67	130537	LOCK NUT M6
68	130538	FUEL SELECTOR SWITCH
69	100586	LOW PRESSURE PIPE LONG
70	100587	LOW PRESSURE PIPE SHORT
71	100588	CLIP $\Phi 12$
72	100589	FUEL HOSE
73	100590	FUEL HOSE
74	100591	TUBE, GLASS FIBER
75	140508	CLIP, FUEL LINE $\Phi 7.5$
76	100592/	CLIP, FUEL LINE $\Phi 9.5$
77	100593	FILTER, FUEL
78	130539	FUEL SELECTOR SWITCH
79	100594	HIGHT PRESSURE VALVE
80	100595	COVER, LPG REGULATOR
81	100596	LOW PRESSURE REGULATOR
0	99546	1.1L OIL BOTTLE
0	100714	REMOTE KEY FOB

Westinghouse Generator Accessories (call to order)	
210004	GENERATOR COVER
210003	WGC25 25' POWER CORD
210052	30A 6 BREAKER TRANSFER SWITCH KIT - MODEL WHMTS30
210075	25' CORD 30AMP TRANSFER SWITCH
210076	50A 6 BREAKER TRANSFER SWITCH KIT - MODEL WHMTS50
210051	25' CORD 50AMP TRANSFER SWITCH
140545	HIGH ALTITUDE CARBURETOR ASSY
140547	PROPANE REGULATOR HIGH ALTITUDE CONVERSION KIT

WGen7500DF ENGINE VIEW

No.	Part.	DESCRIPTION
1	190223	CRANKCASE
2	180593	BALL BEARING
3	180504	OIL SEAL
4	190411	SEAL, GOVERNOR ARM SHAFT
5	190410	SHAFT, GOVERNOR ARM
6	190409	WASHER, GOVERNOR ARM SHAFT
7	190408	PIN, LOCK
8	180507	BOLT DRAIN PLUG
9	180508	WASHER, DRAIN PLUG
10	180586	SWITCH ASSEMBLY, OIL LEVEL

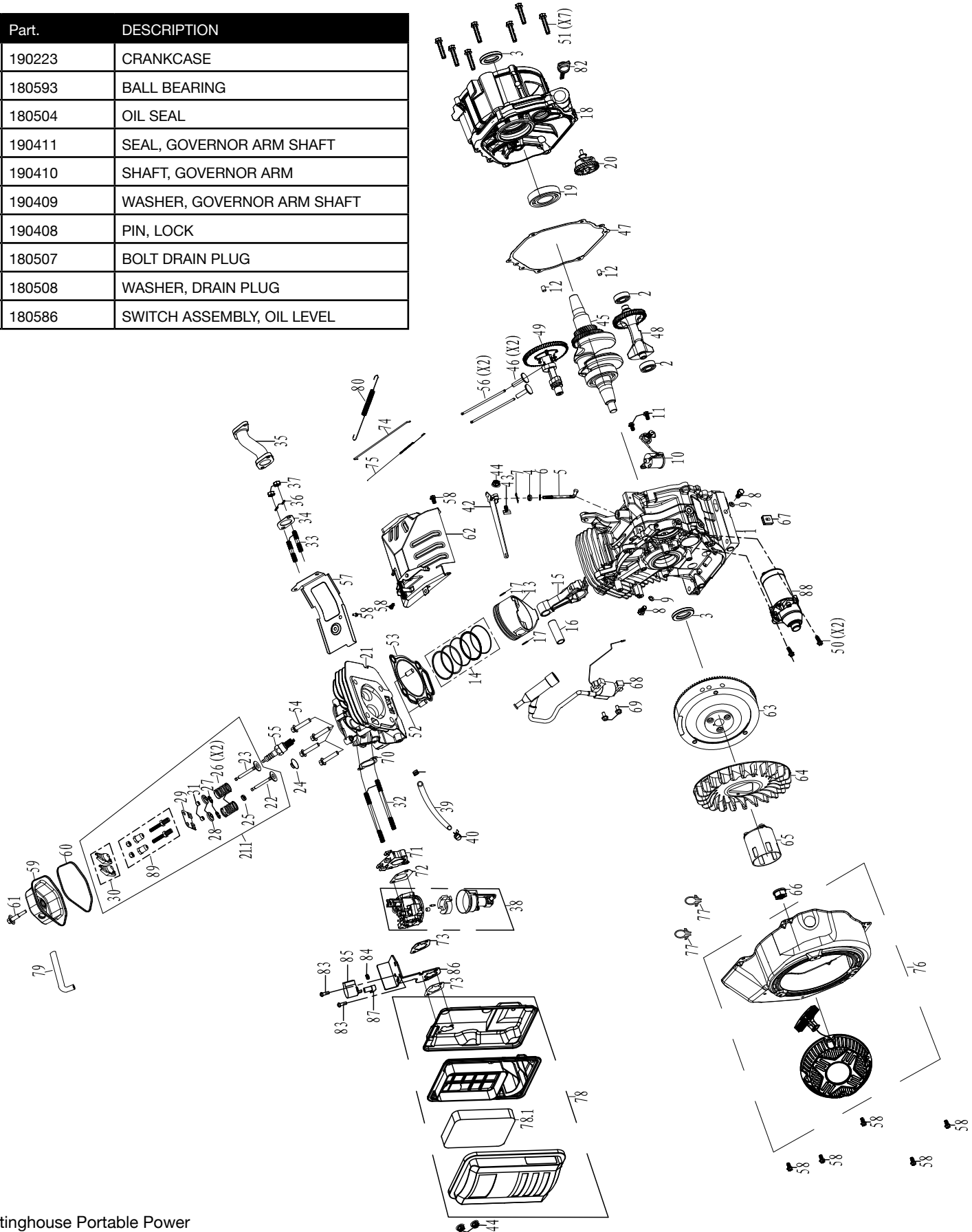

WGen7500DF ENGINE PART NO.

No.	Part.	DESCRIPTION
11	130536	BOLT M6X16
12	180604	DOWEL PIN, CASECOVER
13	190407	PISTON
14	190406	SCRAPER RING SET, PISTON
15	190405	ROD ASSEMBLY., CONNECTING
16	190404	PIN, PISTON
17	180791	CLIP, PISTON
18	180512	COVER ASSEMBLY, CRANKCASE
19	180530	BALL BEARING
20	190225	GOVERNOR ASSEMBLY
21	180514	CYLINDER HEAD
21.1	190417	CYLINDER HEAD REPAIR KIT
22	180743	VALVE, IN
23	180780	VALVE EXHAUST
24	180752	RETURNER, INTAKE VALVE
25	180753	OIL SEAL, VALVE
26	190224	SPRING, VALVE
27	180744	LOCKING FLAPS
28	180755	SEAT, VALVE SPRING, EX
29	180798	PLATE, PUSH ROD GUIDE
30	180799	ROCKER ASSY
31	180756	ROTATOR
32	140503	BOLT, STUD
33	180571	BOLT, STUD
34	180522	PACKING, EXHAUST
35	180521	EXHAUST PIPE
36	110502	SPRING WASHER
37	180524	NUT M8
38	140536	CARBURETOR ASSEMBLY
39	100589	FUEL LINE
40	150549	CLIP, FUEL LINE Ø8.5
41	180589	BOLT M6X8
42	180515	GOVERNOR ARM
43	300075	BOLT,GOVERNOR ARM
44	120506	NUT M6
45	190403	CRANKSHAFT ASSEMBLY
46	190402	LIFTER, VALVE
47	180511	PACKING, CASECOVER
48	190401	BALANCING SHAFT
49	190400	CAMSHAFT ASSEMBLY
50	180807	BOLT M8X35
51	180808	BOLT M8X40

No.	Part.	DESCRIPTION
52	180742	PIN DOWEL
53	180513	GASKET, CYLINDER HEAD
54	180523	BOLT M10X80
55	180526	SPARK PLUG
56	180810	ROD, PUSH
57	180520	SHROUD
58	120505	BOLT M6X12
59	180527	COVER COMP, CYLINDER HEAD
60	180528	HEADCOVER GASKET
61	180529	LOCK BOLT
62	180519	SHROUD ASSY, UPPER
63	180583	FLYWHEEL ASSEMBLY
64	180502	FAN, RECOIL STARTER
65	180501	PULLEY, STARTER
66	180500	NUT
67	180510	RUBBER STARTER ASSY
68	180584	IGNITION COIL ASSY
69	100518	BOLT M6X25
70	140504	PACKING, INTAKE
71	140502	INSULATOR, CARBURETOR
72	140501	PACKING, CARBURETOR
73	140537	GASKET, AIR CLEANER
74	180516	ROD, GOVERNOR
75	180517	SPRING, THROTTLE RETURN
76	170500	RECOIL STARTER ASSEMBLY
77	170502	CLIP
78	160500	AIR CLEANER ASSEMBLY
78.1	160037	AIR FILTER ELEMENT
79	180533	TUBE, BREATHER
80	180518	SPRING, GOVERNOR
81	140506	RUBBER,FUEL
82	180531	DIPSTICK
83	140558	CROSSING SCREW M4*8
84	300500	COMPRESSION SPRING
85	190217	STEPPER MOTOR
86	190192	BRACKET, STEPPER MOTOR
87	140557	STEPPER MOTOR DRIVE SHAFT
88	170503	STARTING MOTOR ASSEMBLY
89	180636	ADJUSTER ROCKER ARM



WestinghousePortablePower.com

Service Hotline: (855) 944-3571

**777 Manor Park Drive
Columbus, OH 43228**

™ & © 2016 Westinghouse Electric Corporation
© 2016 MWE Investments, LLC. All Rights Reserved.

Version 07.25.18KD